

Marketing

市场营销学

Kotler
Keller

市场营销专业 王兰
WangLan@gengdan.edu.cn

Objectives

课程目标

- (1) To introduce the marketing concept and marketing orientation facing to customer.

介绍基本的营销概念和面向顾客的营销导向。

- (2) To encourage students to think about market opportunities by analyzing customers, competitors, collaborators, context.

鼓励学生通过分析顾客、竞争对手、合作伙伴和环境思考市场机会。

- (3) To help students to develop effective segmentation, targeting and positioning.

帮助学生制定有效的市场细分、目标市场选择和定位战略。



- (4) To help students to remember and apply professional English vocabulary.
帮助学生记忆、应用专业的英文词汇。
- (5) To cultivate student's communicative, cooperative and suggestive competence.
培养学生沟通、合作和建议能力。
- (6) To promote group work.
促进团队合作。

Contents

课程内容

Topic 1	Understanding Marketing Management Process 理解营销管理
Topic 2	Capturing Marketing Insights 获取营销洞见
Topic 3	Connecting with Customers 与顾客建立联接
Topic 4	Building Strong Brands 建立强势品牌
Topic 5	Creating Value (Product Strategy) 创造价值（产品策略）
Topic 6	Reflecting Value(Price Strategy) 体现价值（价格策略）
Topic 7	Delivering Value(Place Strategy) 传递价值（渠道策略）
Topic 8	Communicating Value(Promotion Strategy) 传播价值（促销策略）

References

参考阅读

Books	1. Philip Kotler,15th(2019), Marketing Management, Pearson
Open Class	http://open.sina.com.cn/course/id_883/



Philip Kotler

Father of Modern Marketing

现代营销学之父

Distinguished Professor of International Marketing at the Kellogg School of Management at Northwestern University.

西北大学凯洛格管理学院终身教授

<Marketing Management> is the most widely used marketing textbook worldwide.

《营销管理》是世界范围内使用最广泛的营销学教科书

Kotler
Keller

1

**Defining Marketing
for the New Realities**
定义营销新现实

What is Marketing?P6

Marketing is the activity , set of institutions , and processes for creating, communicating, delivering, and exchanging **offerings** that have value for customers, clients , partners , and society at large. (AMA,2007)

市场营销是创造、传播、传递和交换对顾客、客户、合作者和整个社会有价值的**产品**的一系列活动、制度和过程。(AMA,2007)

What is Marketing Management?

P6

Marketing management is the *art and science* of choosing target markets and getting, keeping, and growing customers through creating, delivering, and communicating superior customer value.

- **营销管理**是选择目标市场并通过通过创造、传递和传播卓越顾客价值，来获取、维持和增加顾客的**艺术**和**科学**。



鸿星尔克官方微博

+关注

7-21 17:45 来自 iPhone客户端

守望相助，风“豫”同“州”，我们在一起!

鸿星尔克心系灾区，通过郑州慈善总会、壹基金紧急捐赠

5000万元物资，驰援河南灾区，河南加油!

#河南挺住我们来了#



一份责任心，成就一个企业

全面“封杀”王老吉

2008年5月18日，加多宝集团地震捐款1亿元。第二天，王老吉受到热捧，网友号召：全面“封杀”王老吉，超市有一瓶买一瓶。



汶川地震期间最火的帖子 ——封杀王老吉

- 不能再让王老吉的凉茶出现在超市的货架上，见一罐买一罐，坚决买空王老吉的凉茶，今年爸妈不收礼，收礼就收王老吉。支持国货,以后我就喝王老吉了,让王老吉的凉茶不够卖!让他们着急去吧!

What is Marketed?P6



- Goods 产品
- Services 服务
- Events 事件
- Experiences 体验
- Persons 人物
- Places 地点
- Properties 财产
- Organizations 组织
- Information 信息
- Ideas 观念

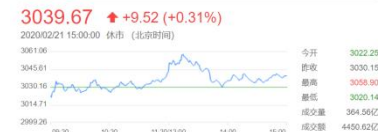
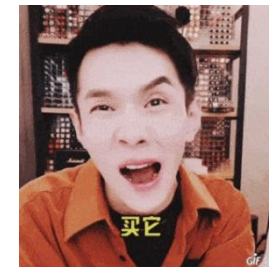

Who Markets? P7

谁来执行

- A **marketer** is someone who seeks a response attention, a purchase, a vote, a donation from another party, called the **prospect**.
- 营销者是那些从潜在顾客那里寻求响应的人，如寻求他们的注意力、购买行为、选票或捐赠等。
- Marketers are indeed skilled at stimulating and influencing demand for their company's products.
- 营销者往往很擅长刺激和影响消费者对其公司产品的需求。

Demand States(P8)

需求状态

- Negative 负需求
- Nonexistent 无需求
- Latent 潜在需求
- Declining 下降需求
- Irregular 不规则需求
- Unwholesome 不健康需求
- Full 充分需求
- Overfull 过度需求



Hunger Marketing 饥饿营销





How do you sell the ice to Eskimo
如何把冰卖给爱斯基摩人

Creative Development Practice
创意拓展训练

How do you sell the ice to the world?
如何把冰卖给全世界

Core marketing concepts p9

市场营销中的核心概念

需要、欲望和需求

- Needs (需要) are the basic human requirements such as for air, food, water, clothing, and shelter. 是人类对空气、食物、水、穿着和居所的基本的需求。
- These needs become wants (欲望) when directed to specific objects that might satisfy the need. 这些需要在指向可以满足需要的特定目标时就成为欲望。

Core marketing concepts p9

市场营销中的核心概念

需要、欲望和需求

- Demands (需求) are wants when directed to specific products backed by an ability to pay. 是可以被购买能力满足的对特定产品的欲望。

马斯洛需求层次理论（模型）

亚伯拉罕·马斯洛
(**Abraham Maslow**
, 1908年4月1日 -
1970年6月8日), 美国
人本主义心理学家, 以需
求层次理论 (Need-
hierarchy theory) 为
世人熟悉。



自我实现的需求

对理想实现等的需要
也称成长需要

想被他人承认的需要

社会需要, 与他人交流
相关的需要变得更重要

避免对生命构成威胁的
需要

本能层次的需要, 包括
食欲、睡眠、欲望等



本文档已声明符合Creative Commons的使用权限
署名-非商业性使用-禁止演绎 www.ilenin.com

马斯洛这一理论在营销中主要应用于研究消费者的购买动机, 购买时的心理, 购买后所达到的预期感受等。

Segmentation (市场细分)、Target markets(目标市场) and Positioning(市场定位)



Offerings and Brands

产品和品牌

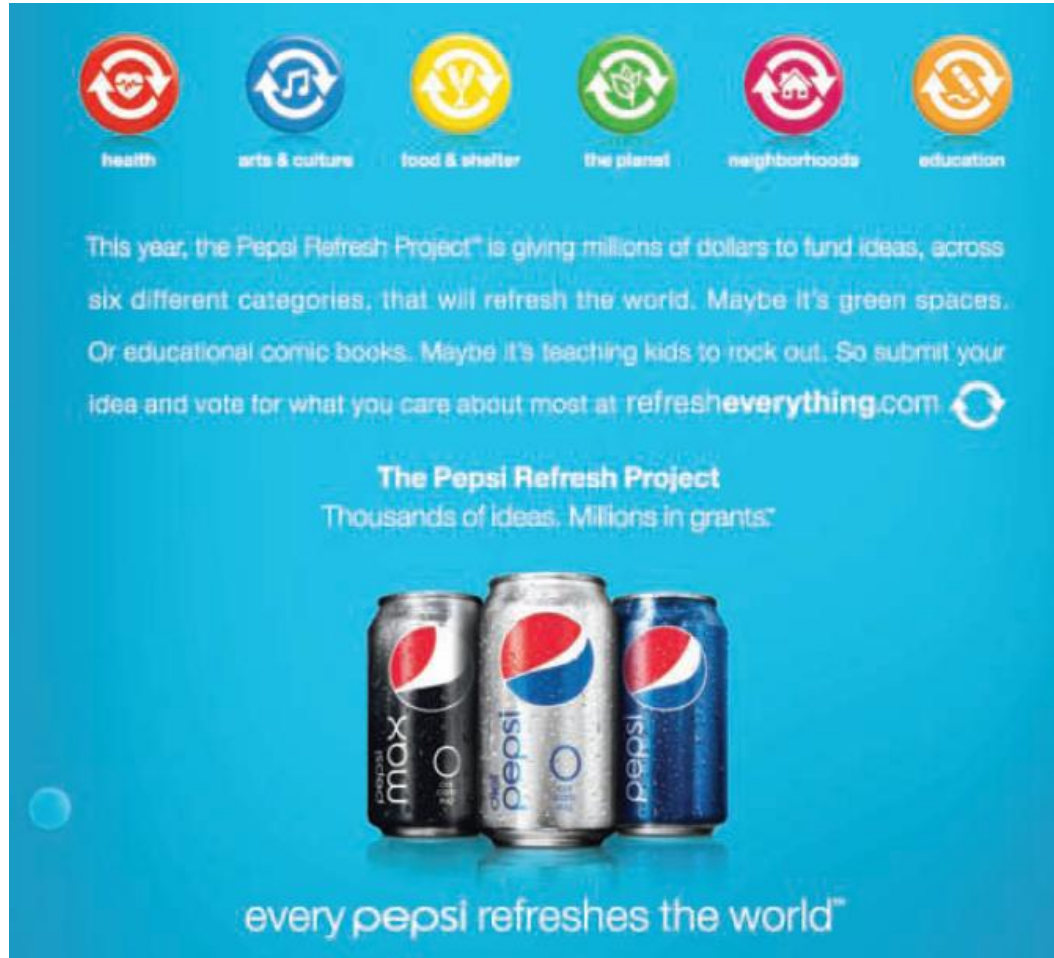

health arts & culture food & shelter the planet neighborhoods education

This year, the Pepsi Refresh Project™ is giving millions of dollars to fund ideas, across six different categories, that will refresh the world. Maybe it's green spaces. Or educational comic books. Maybe it's teaching kids to rock out. So submit your idea and vote for what you care about most at refresheverything.com 

The Pepsi Refresh Project
Thousands of Ideas. Millions in grants.*



every pepsi refreshes the world™



Marketing Channels

营销渠道

Communication Channel
传播渠道

Distribution Channel
分销渠道

Service Channel
服务渠道



Paid media、Owned media and Earned media

付费媒体、自有媒体和免费媒体



Impression and Engagement

印象与融入



Value and Satisfaction

价值与满意度

L.L.Bean SINCE 1912 | FALL 2001

from the first falling leaves
of autumn, our soft, warm
fitness fleece is an ideal layer
to chase away the chill



LLBEAN.COM | FAST, RELIABLE DELIVERY

Supply Chain (供应链)

- The supply chain is a longer channel stretching from raw materials to components to finished products carried to final buyers.
- 供应链包括了从原材料和零部件的供应到把产成品交付给最终顾客的整个过程。

Competition (竞争)





Marketing Environment

市场营销环境

- Task Enviroment任务环境（微观）
- Broad Enviroment宏观环境

Company Orientation 营销导向 (Marketing Concept 营销观念) P20

- The marketing concept and philosophy states that the organization should strive to satisfy its customers' wants and needs while meeting the organization's goals.
- 市场营销的概念和哲学指出，组织应该在实现目标的同时努力满足客户的需求。

The Production Concept

生产观念

- Time: the late 19th century and the early 20th century
- Background: Seller's Market
- Core Idea: Production-Centric Theory 生产中心论
- The order of marketing: Business to Customer

Ford Model T



The Product Concept

产品观念

- Time: the late 19th century and the early 20th century
- Background: Customer like high quality product
- Core Idea: Marketing Myopia 营销近视症
- The order of marketing: Business to Customer



The Selling Concept

推销观念

- Time: in the 1930s and 40s
- Background: Market was from seller's market to buyer's market
- Core Idea: Use the selling and promotion to stimulate the demands运用推销与促销来刺激需求的产生
- The order of marketing: Business to Customer

The Marketing Concept

营销观念/市场营销观念

- Time: in the 1950s
- Background: Buyer's Market
- Core Idea: Consumer Sovereignty 消费者主权论
- The order of marketing :

Market→Business→Product→Market

The company orientation for GM



The Holistic Concept

全方位营销观念

- Time: in the 1970s
- Background: Social Problem Arising
- Core Idea: Marketing=Demands + Social Benefit + Profit Target 盈利目标
- The order of marketing :

The whole society→Business→Product→Market



Thank you!



**Kotler
Keller**

2
**Collecting Information
and
Forecasting Demand**
信息收集和 demand 预测

Case:

Haier



海尔无所不洗





What is a Marketing Information System? 什么是营销信息系统？

P61

A **marketing information system** consists of people, equipment, and procedures to gather, sort, analyze, evaluate, and distribute needed, timely, and accurate information to marketing decision makers.

营销信息系统由人员、设备和程序构成，它对信息进行收集、分类、分析、评估和分发，为决策者提供所需的及时和精确的信息。

Internal Records System

内部报告系统(P62)

- Order-to-payment cycle
订单付款周期
- Sales information system
销售信息系统
- Databases, warehousing, data mining
数据库、数据存储和数据挖掘

Big data, Cloud computing



What is a

Marketing Intelligence System?

营销情报系统 P62

A marketing intelligence system is a set of procedures and sources that managers use to obtain everyday information about developments in the marketing environment.

是指管理者使用的一整套程序和信息来源，用以获得有关营销环境发展变化的日常信息。

Steps to Quality Marketing Intelligence

提高营销情报质量的步骤 P63-P65

- Train and motivate sales force to spot and report new developments
训练和鼓励销售人员现场观察和及时报告最新进展
- Motivate distributors , retailers and other intermediaries to pass along intelligence
激励分销商、零售商和其他中间商提供重要情报
- Hire external experts to collect intelligence
聘用外部专业人员收集情报

mystery shopper

- Network internally and externally

内部与外部网络

- Set up a customer advisory panel

Focus Group

建立顾客咨询小组

- Utilize government data sources

利用政府数据资源



- Buy information from outside research firms and vendors.

从外部调研公司和供应商处购买信息

- Collect marketing intelligence on the internet.

在线收集营销情报

How to communicate and use the marketing information?



The screenshot shows the Dangdang.com website interface. At the top, the logo '当当网' (Dangdang.com) is visible with the tagline '网上购物享当当'. Below the logo, there are navigation links for '首页' (Home), '图书' (Books), '数字馆' (Digital Library), '美妆' (Beauty), '家居' (Home), and '孕婴童' (Pregnancy, Infants, and Children). A secondary navigation bar includes '图书畅销榜' (Bestselling Books), '百货畅销榜' (Bestselling Goods), '商品团购' (Group Buying), '特价书市' (Special Price Book Market), '当当优品' (Dangdang Premium), '苹果' (Apple), and '台湾' (Taiwan). A sidebar on the left lists '全部商品' (All Products) with categories: '图书、电' (Books, Electronics), '家用电器' (Home Appliances), '手机数码' (Mobile Phones, Digital), '电脑、办' (Computers, Office), '家居家装' (Home Decor), '服饰鞋帽' (Clothing, Shoes), '个护化妆' (Personal Care, Cosmetics), and '礼品箱包、钟表、珠宝' (Gifts, Bags, Watches, Jewelry).





The purpose of
environmental analysis

环境分析的目的

Seek the opportunities!

寻求商机

Avoid the crisis!

避免危机

Case: P&G's Lesson

The diaper is too thick.



Germany Baby

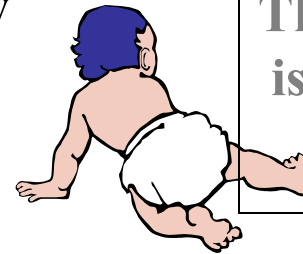

The diaper is too thin.

No trial sale.

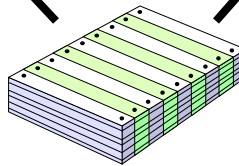

The diaper of P&G.

All diapers are the same.

Major Forces in the Environment

环境中的主要要素

Demographic
人口

Political-legal
政治法律

Economic
经济

Technological
技术

Socio-cultural
社会文化

Natural
自然

Population and Demographics

人口统计环境 P66

- Worldwide Population Growth 世界人口增长
- Population Age Mix 人口年龄结构
- Ethnic Markets(Socio-cultural?) 种族市场
- Educational Groups 教育人口群体
- Household Patterns 居户类型
- Population Gender 人口性别
- Geographic Distribution 地理分布



1、 Population Growth

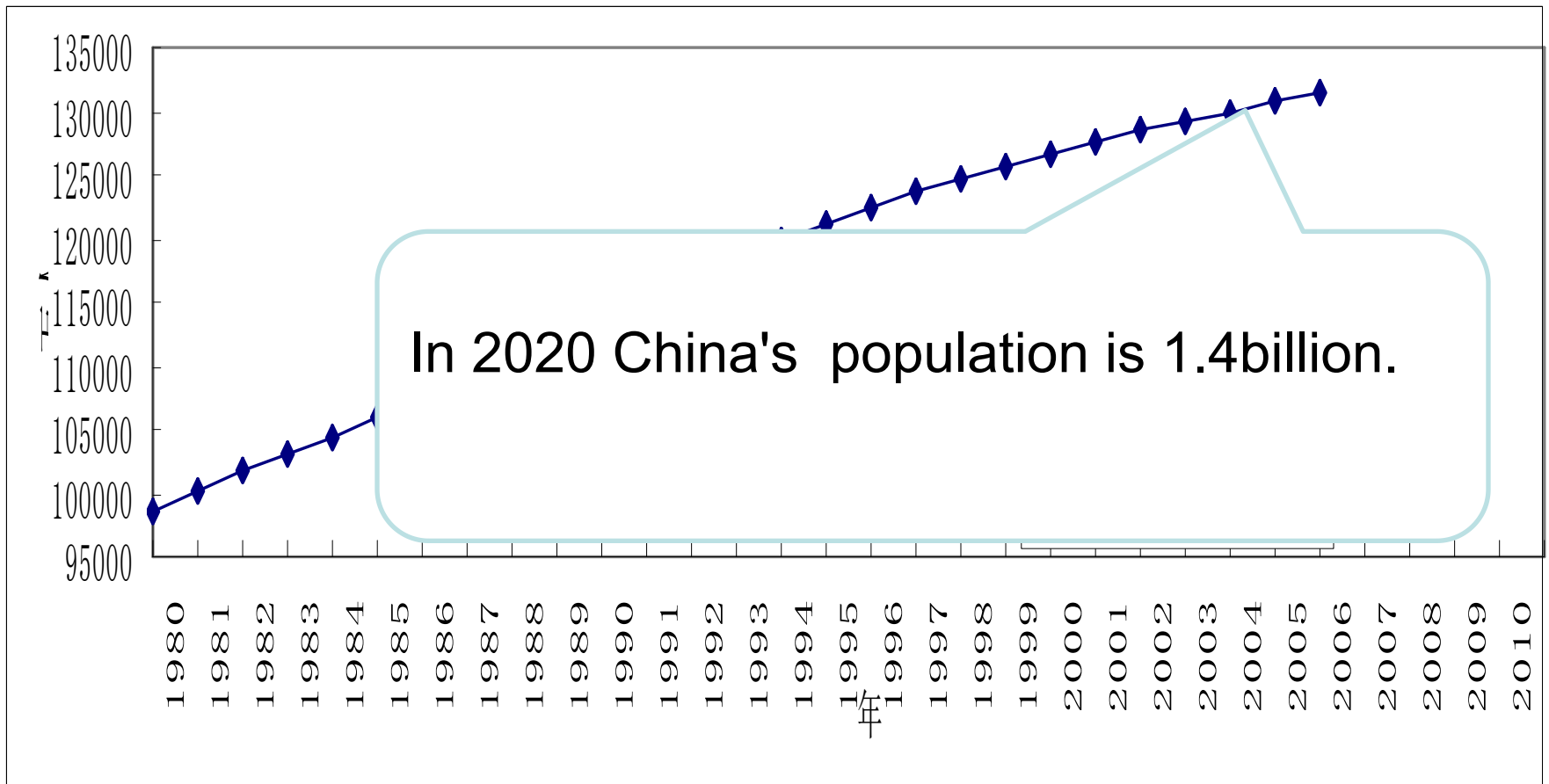



(1) The
rapid

It totaled

(2) The
down



es

Jap
enc

state policy in 2003.

Top 10 countries with population

2010	2050
1. China	1. India
2. India	2. China
3. The United States	3. The United States
4. Indonesia	4. Indonesia
5. Brazil	5. Pakistan
6. Pakistan	6. Brazil
7. Bangladesh	7. Nigeria
8. Nigeria	8. Bangladesh
9. Russia	9. Democratic Republic of Congo
10. Japan	10. Ethiopia



- 2、Population Age Mix人口年龄结构
- The aging population is accelerating in many countries.许多国家人口老龄化加速
- The decline in the birth rate has caused a change in market demand.出生率下降引起市场需求变化

0—14岁人口为253383938人，占17.95%；15—59岁人口为894376020人，占63.35%；60岁及以上人口为264018766人，占18.70%，其中65岁及以上人口为190635280人，占13.50%。与2010年第六次全国人口普查相比，0—14岁人口的比重上升1.35个百分点，15—59岁人口的比重下降6.79个百分点，60岁及以上人口的比重上升5.44个百分点，65岁及以上人口的比重上升4.63个百分点。

Group Discussion:

- What social problems will be caused by the aging society?
- Which industries will have opportunities as the population ages? Why?

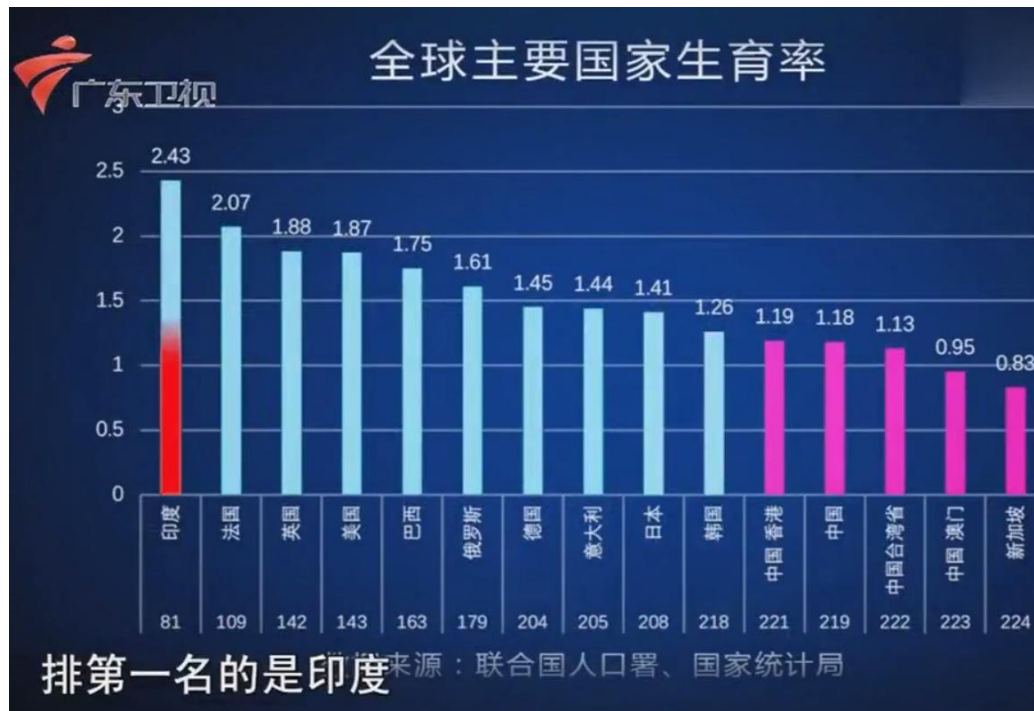

3、Education Groups教育人口群体

- Illiterates, High School Dropouts, High School Diplomas, College Degrees, and Professional Degrees. (Foreign Classification)

文盲、高中肄业、高中毕业、大学学位或职业教育学位。（国外分类标准）

- Illiterates ,Primary Diplomas,、 Middle School Diplomas, High School Diplomas, and College Degrees and Above. (China Classification)

文盲、小学、初中、高中、大学及以上（中国分类标准）



(六)受教育程度人口。具有大学[文化](#)程度的人口为21836万人。与2010年相比，每10万人中具有大学文化程度的由8930人上升为15467人，15岁及以上人口的平均受教育年限由9.08年提高至9.91年，文盲率由4.08%下降为2.67%。受教育状况的持续改善反映了10年来我国大力发展[高等教育](#)以及扫除青壮年文盲等[措施](#)取得了积极成效，人口素质不断提高。





- 4、Household Patterns 家庭类型
- More people are divorcing or separating, choosing not to marry, marrying later, or marrying without the intention to have children. 越来越多的人选择离婚、不婚、晚婚或结婚不要孩子。
- Global household size is reducing.
- Average household size of census in china.

2010: 3.10
2020: 2.62

- 1953: 4.33
- 1964: 4.43
- 1982: 4.41
- 1990: 3.96
- 2000: 3.44



- 5、Population Gender人口性别
- The male share of the population is 51.24% in 2020 in china.
- Male cosmetic appeared.

男士彩妆套装十大品牌排行榜

排行榜123网依托全网大数据，根据品牌评价以及销量评选出了2021年男士彩妆套装十大品牌排行榜，前十名分别是左颜右色、尊蓝、泊泉雅、和风雨、雅邦、爵色、阿芙、梵可、欧菲姿、Chetti Rouge。如果您正在查找男士彩妆套装什么牌子好？那么本男士彩妆套装十大品牌榜单可供您作为选购参考，我们致力于用最真实的用户数据推荐口碑最好的男士彩妆套装品牌，让您选得放心。(榜单每月更新一次)



-
-
-

/

the
ed

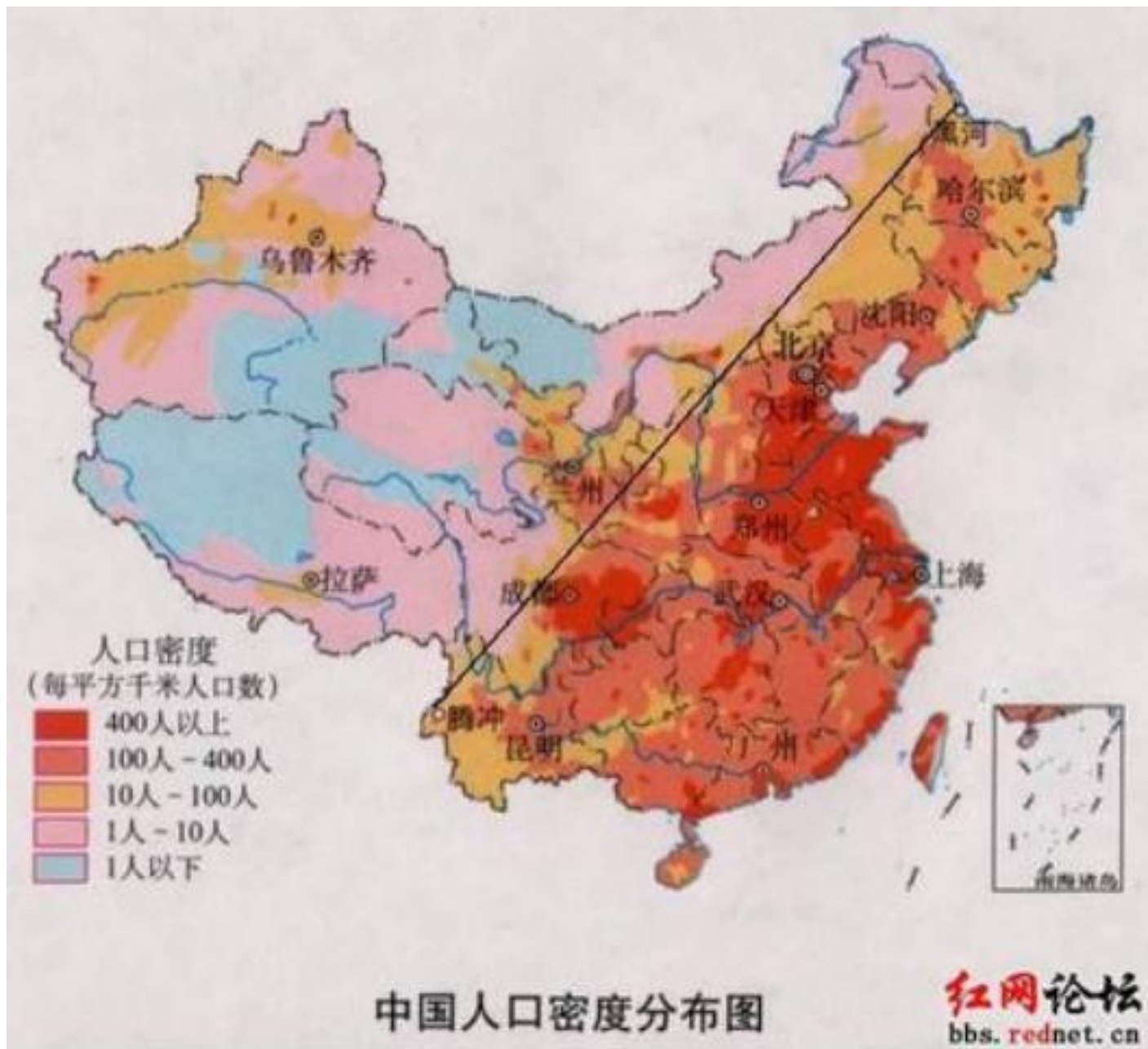

Economic Environment 经济环境

P69

Income 收入

Expenditure 支出

Savings, Debt, Credit 储蓄、负债、信贷

- 
- 1、Income收入
 - Personal Income个人收入

Total compensation received by an individual.

个人获得的全部报酬

It refers to the level of purchasing power.

反映了购买力水平

Disposable Personal Income=PI-Income Tax-Current

Transfers=Personal Consumption + Saving/Investment

个人可支配收入（DPI）= PI—所得税—经常性转移支出= 个人消费+
储蓄/投资

Discretionary Income=

DPI- Saving-Paying for Personal Necessities

可任意支配收入



= DPI—储蓄—购买生活必需品的固定开支

Group Discussion:

- How to know the market size for luxury brand?

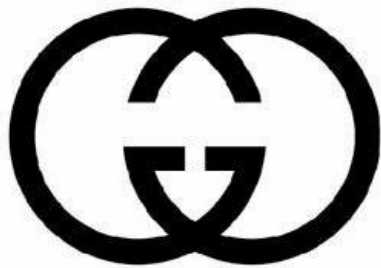
GUCCI



- 
- 2、Expenditure支出
 - It refers to the expenditure pattern and consumption structure.
 - 主要是指消费者支出模式和消费结构。
 - It is measured by Engel coefficient/ Engel's law.
 - 主要采用恩格尔系数来衡量。
 - Engel coefficient/ Engel's law is the proportion of income spent on food.
 - 恩格尔系数为食物支出占个人总支出的比例。
- 

- 
- According to the standards set by the Food and Agriculture Organization of the United Nations (联合国粮农组织) .
 - Over 59% Poor 贫困
 - 50%~59% Food-and-Clothes Sufficient 温饱
 - 40%~50% well-off 小康
 - 30%~40% Affluent 富裕
 - Below 30% Extremely Affluent 最富裕

- 3、Savings, Debt, Credit
- 储蓄、债务、信贷



Case:

- James Hilton and “Lost Horizon”
- Diqing Tibet Autonomous Prefecture, Yunan province.



Subculture 亚文化P71

- Subculture is a group of people shared values, beliefs, preferences, and behaviors emerging from their special life experiences or circumstances.
- 亚文化：即特定的生活经历或生活环境形成的共同信仰、爱好和行为的群体。
- Including: Regional Subculture 区域亚文化;
Ethnic Subculture 民族亚文化;
Racial Subculture 种族亚文化;
Religious Subculture 宗教亚文化.

	喜欢色彩	厌恶色彩
英国	红白蓝色组	绿色
法国	灰、白、粉红	墨绿、黄
德国	鲜明色彩	茶色、黑色、深蓝色、
日本	黑色、紫色、红色	绿色
印度	白色	红色、橘黄色
伊斯兰 国家	绿色	蓝色
新加坡	绿色、红色	黄色
港澳	蓝色、白色	-
泰国	黄色	绿色、红色
巴西、 秘鲁	-	紫黄、暗茶色

Saint Patrick's Day in Ireland



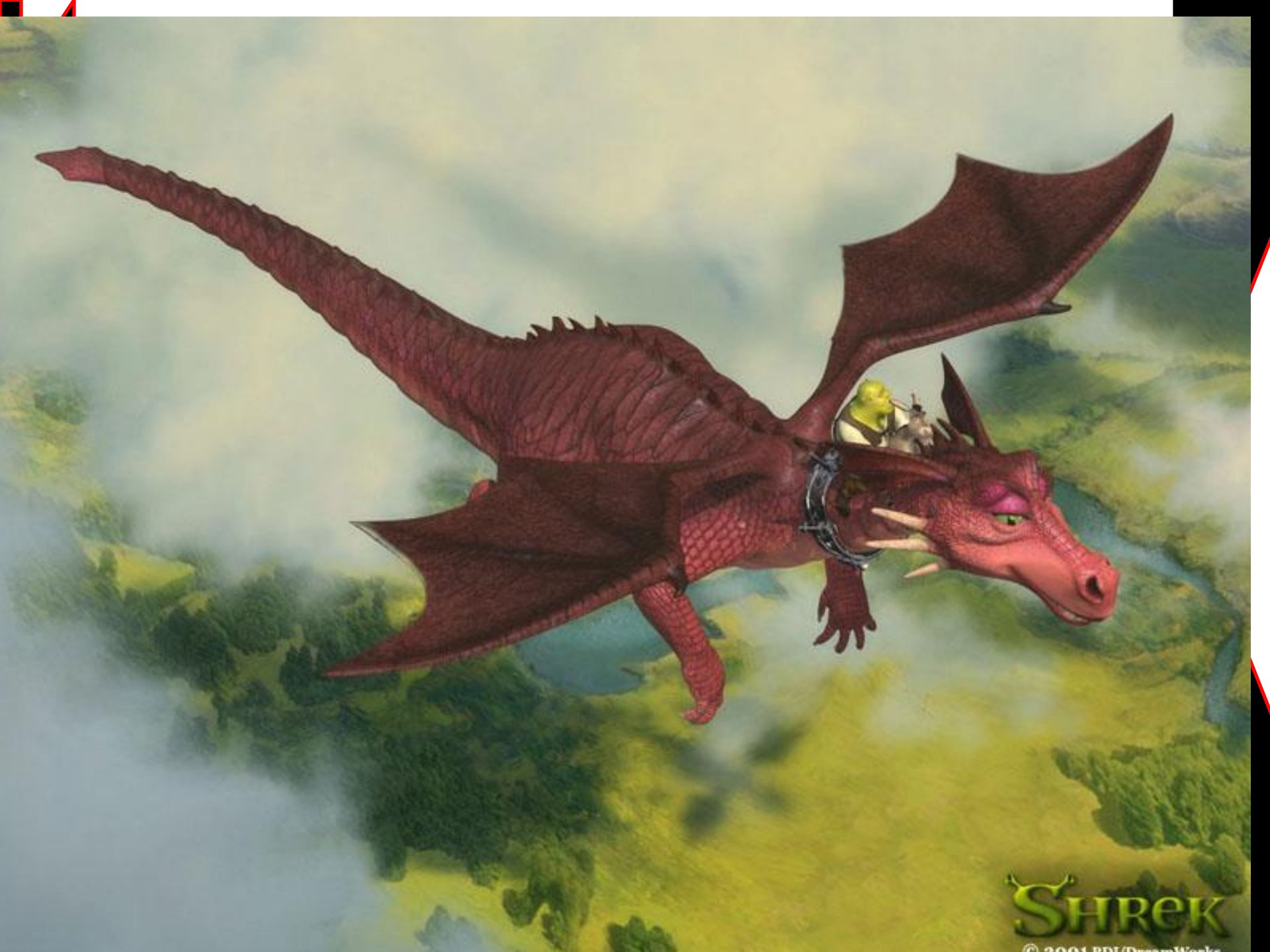

SHREK
© 2001 PDI/DreamWorks

- Ethnic Subculture
- ✓ China (56 ethnic groups)



Mosuo People by Lugu Lake of Yunnan

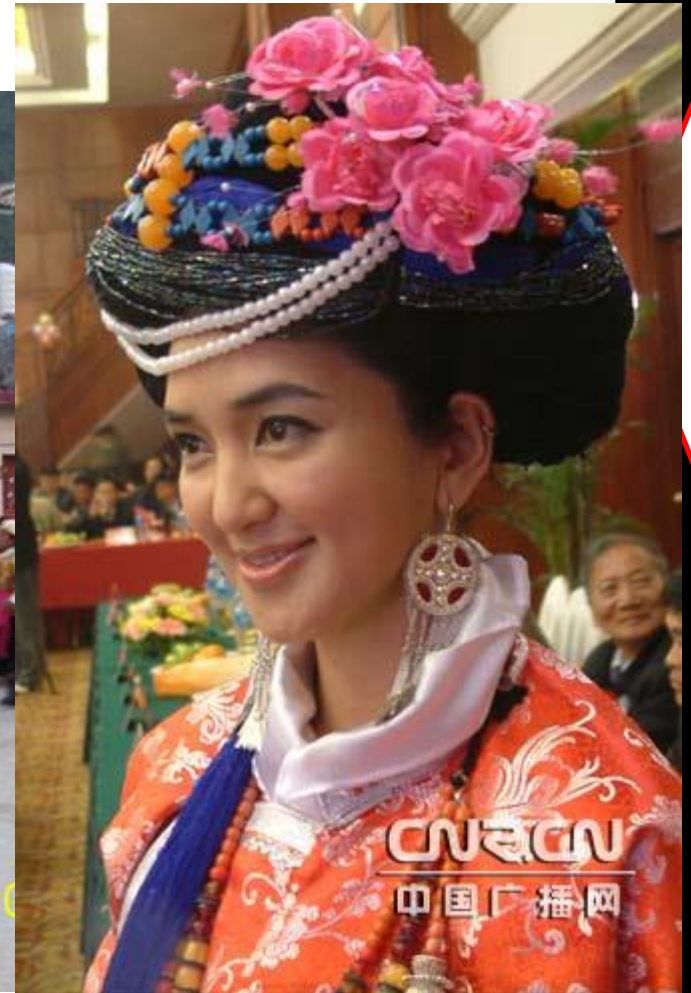

- Racial Subculture
- HIP-HOP





- Religious Subculture





Superstition迷信



十二生肖
辰龙
CHINESE ZODIAC
DRAGON



Natural Environment 自然环境

P72

- Shortage of raw materials 原料短缺
- Increased energy costs 能源成本的增加
- Anti-pollution pressures 反污染的压力
- Governmental protections 政府的环保

“拉闸限电”是一场中美博弈？深度解读限电背后的真相|大耳讲财经

2021-10-08 10:34:21 06:14 9.6万



辽宁的供电缺口仍然到了严重的程度

2:24 / 6:14

BMW Great Wall Joint Venture



大家好，我给你们介绍一下，
这是我的女朋友@BMW



Technological Environment

技术环境 72

- Pace of change 技术变革步伐加快
- Opportunities for innovation 无限的创新机会
- Varying R&D budgets 差异较大的研发预算
- Increased regulation of change 科技变动管理的增加

Discussion:

- What new technologies are changing consumer behavior?
- 有哪些新技术改变了消费者的行为?

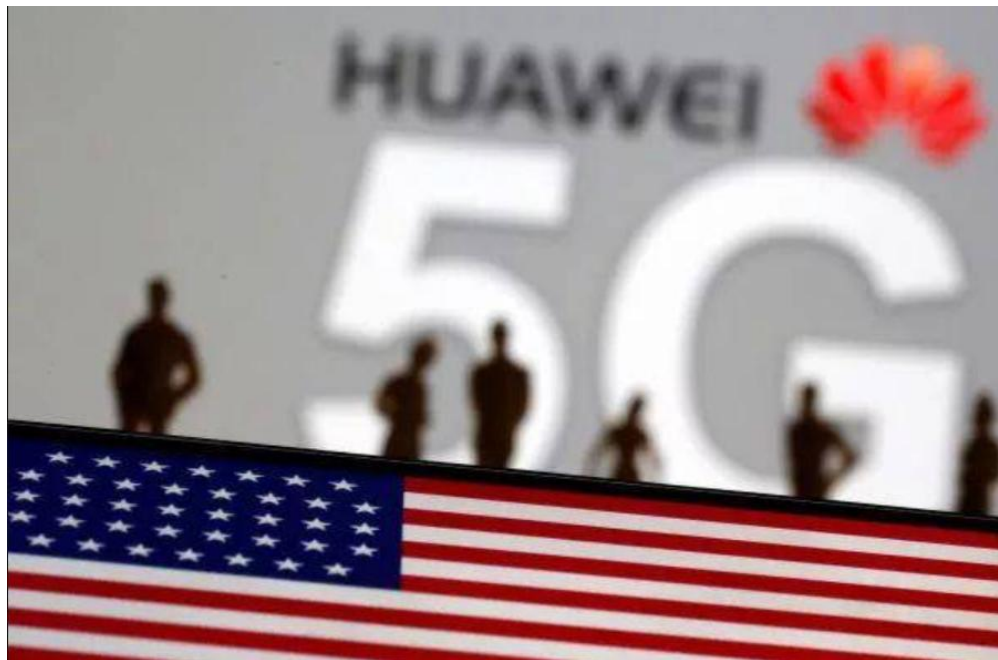

新的商业模式案例分析



The Political-Legal Environment

政治法律环境 75

Business Legislation
商业立法

Policy
政策

Antitrust Law 反垄断法





小肥羊 火锅餐厅
LITTLE SHEEP HOT POT



1999年
张钢成立小肥羊饭店



2001年
7月
连锁店整合以及股份制改革，内蒙古小肥羊餐饮连锁有限公司诞生



2002年
小肥羊的营业额达到25亿元，一跃成为中国本土餐饮业的老大



2012年
2月
百胜以近46亿港元现金完成对小肥羊的私有化，使其总持股量达93.2%



2006年
6月12日
小肥羊登陆港交所主板，成为第一家在香港上市的国内餐饮企业



2004年
小肥羊以43.3亿元的营业额名列全国餐饮企业百强第二



小肥羊 火锅餐厅
LITTLE SHEEP HOT POT



- Thanks



**Kotler
Keller**

3

**Creating Long-Term
Loyalty Relationships
创造长期顾客忠诚**

Figure 5.1 Customer-Orientations

P114

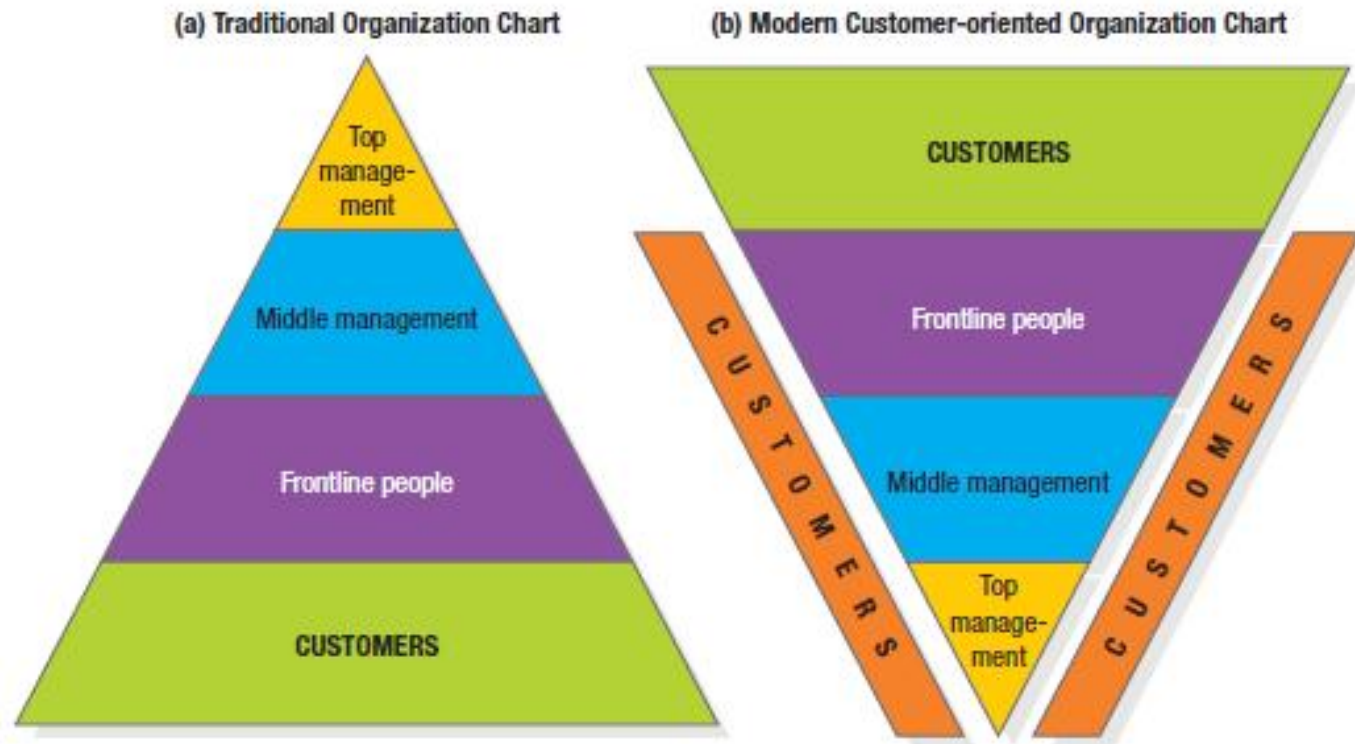

Dell Reestablished Its Commitment to Value



Total Customer Satisfaction

总体顾客满意

(P119)

Satisfaction is a person's feelings of pleasure or disappointment that result from comparing a product's perceived performance(or outcome/*value*) to their expectations.

满意度是指一个人对产品或服务的感知性能（或结果）与期望之间比较后的愉悦或失望的感觉。

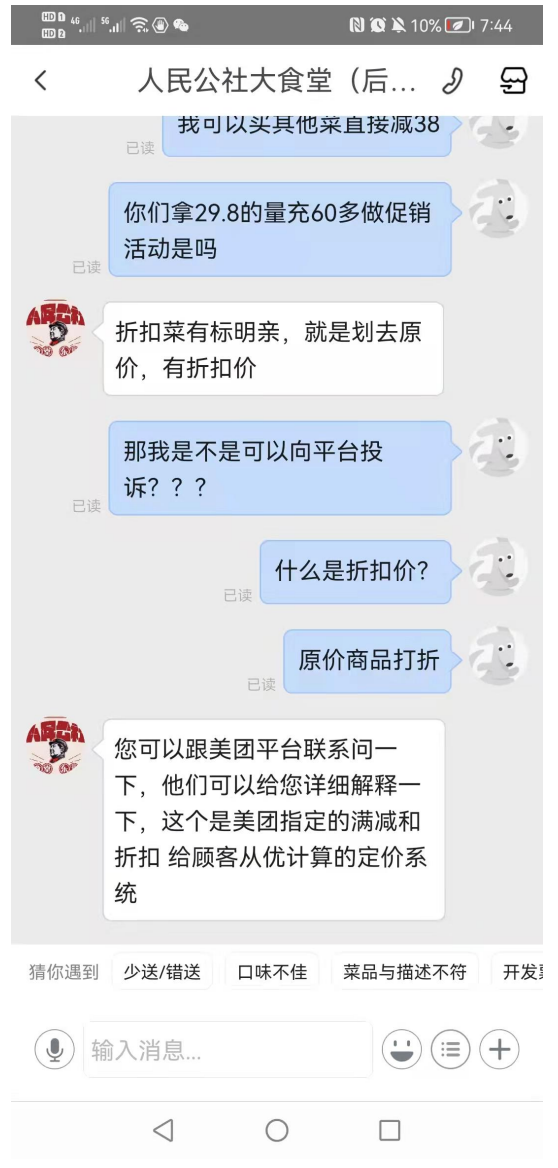
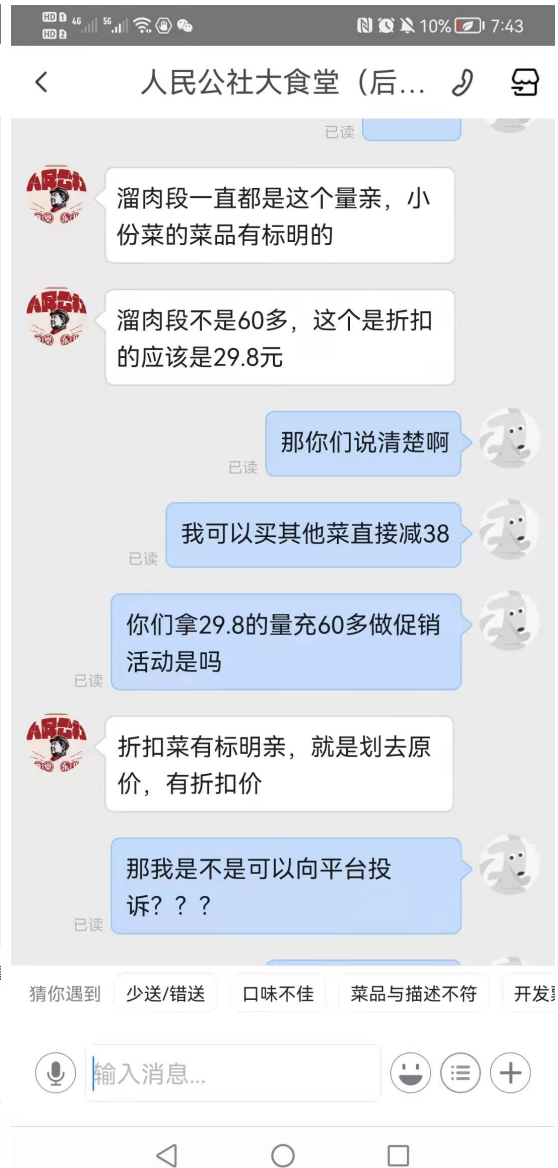



服务进度



服务进度



服务进度

卖家虚假宣传拿26元的商品充60元的商品然后打折，说是折扣商品，原本就是26元的商品根本不存在折扣价，卖家自己也承认，有图片为证！！

 **人民公社大食堂 (后...** 订单完成
不需要餐具等7件商品 实付 ¥103.46

但是量不是60的菜量

商家就是按29.6做的菜量

说是今天做促销折扣原价60多现价29

是不是虚假宣传

?

尊敬的用户 是这笔订单嘛

嗯，是这个订单

是这个订单

这边看到这笔订单 这个菜品的价格是29.8 的亲

是显示的折扣价

实际是60多

嗯嗯 您支付后就是折扣的价格呢

小美这边会如实记录反馈商家的问题给商家管理部门商家管理部门会对商家重新考核下降排名 再决定是否合格的

亲，小美这边非常理解您的心情，为您申请一张 20元外卖通用红包。您可以通过外卖APP-我的资产-红包进行查看。但每笔订单需最少支付0.01元，如抵扣金额小于红包金额，则需支付0.01元。红包有效期31天，请您注意在有效期前使用。红包仅限下单



今天 19:48

今天 19:50

显示今天做活动所以29.8

请用一句话描述您的问题

请用一句话描述您的问题

请用一句话描述您的问题





Monitoring Satisfaction

监测顾客满意 (P119)

- Periodic Surveys 定期调查
- Customer Loss Rate 顾客流失率 (CRM P132)
- Mystery Shoppers 神秘顾客

What is Customer Perceived Value? 什么是顾客感知价值 (P115)

- **Customer perceived value** is the difference between the prospective customer's evaluation of all the benefits and all the costs of an offering and the perceived alternatives.
- 顾客感知价值是指潜在顾客对特定的产品及感知的替代品的全部利益的评价减去全部成本的评价之差。

Figure 5.2 Determinants 決定因素 of Customer Perceived Value P116

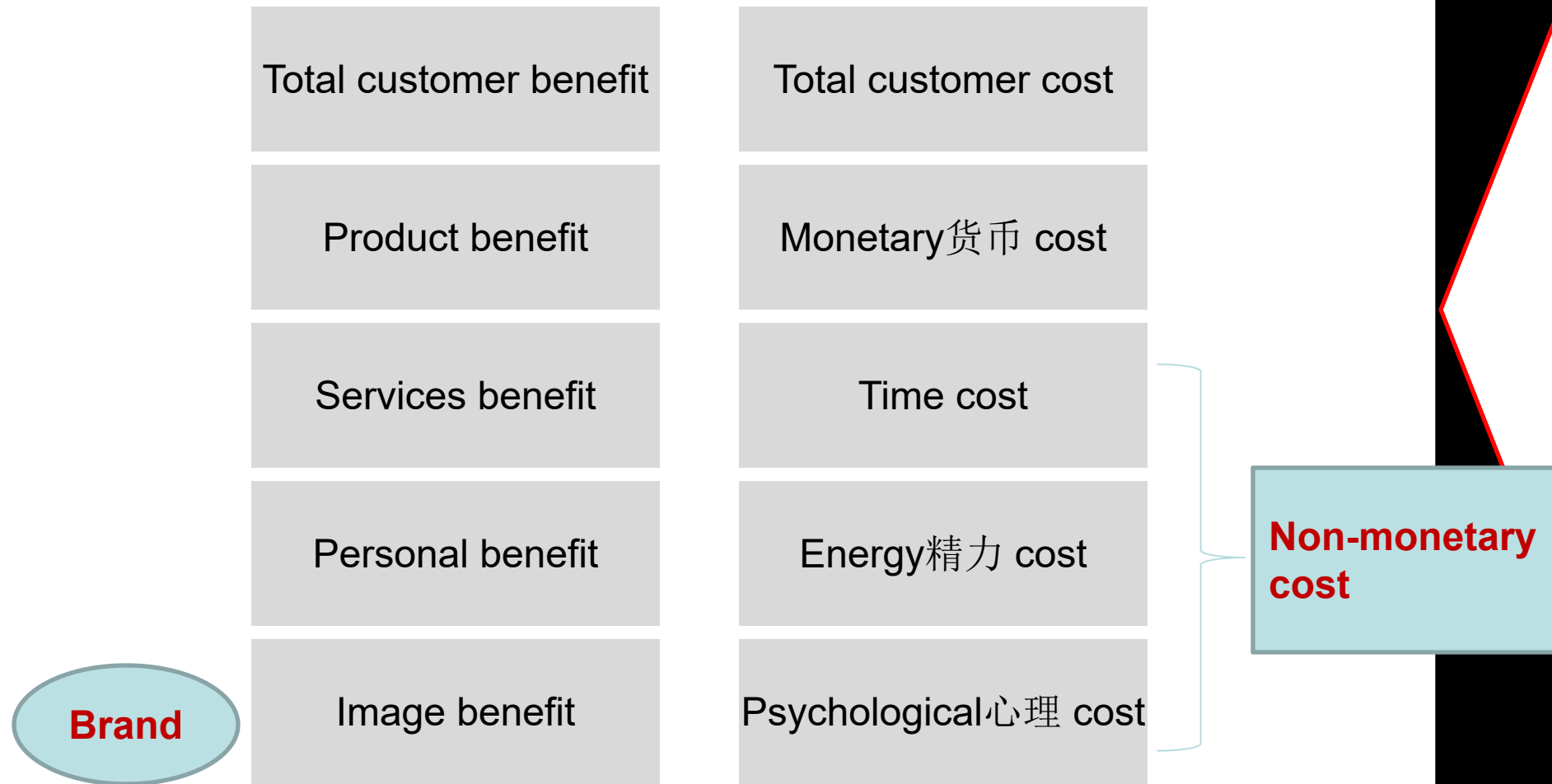



How to improve customer satisfaction?

- Customer satisfaction=Performance-Expectation
 - Performance=Total benefit-Total cost
- 

Group Discussion

- What are some specific ways that smart phones (you can choose any brand) can improve customer value?



What is Customer Relationship Management?(P132)

CRM is the process of carefully managing detailed information about individual customers and all customer touch points to maximize customer loyalty.

客户关系管理是谨慎地管理单个客户和所有客户“接触点”的细节，以最大限度地提高其忠诚度的过程。



P132

- Personalizing personnel can build relationships with customers by personalizing relationships. 个性化服务可以建立顾客关系。

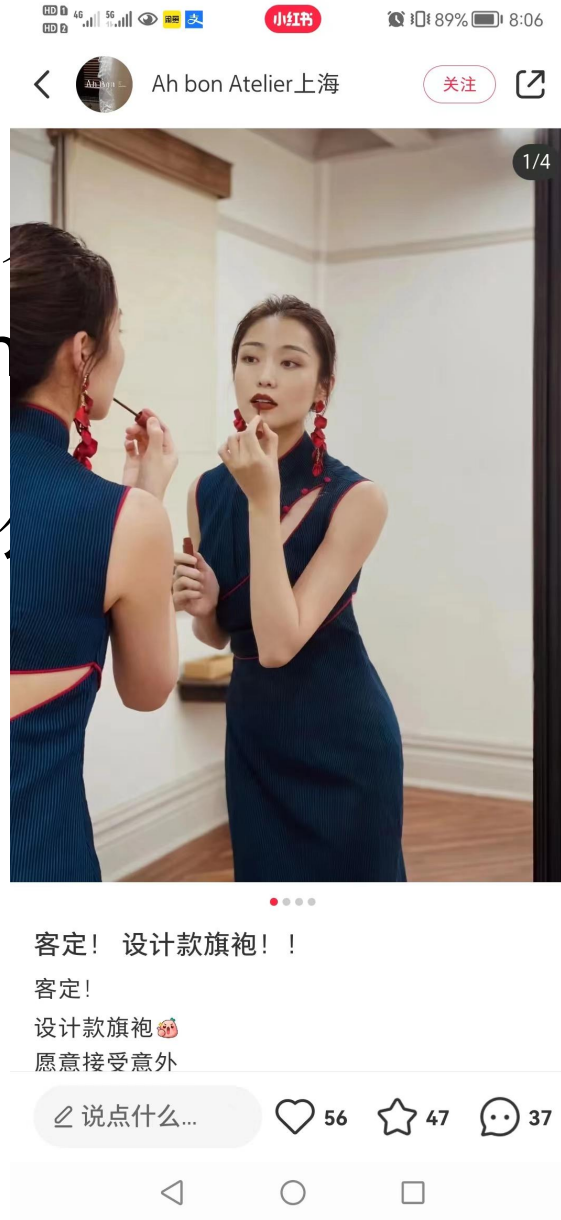

Company
nds with
d personalizing
私人化来建立

- **Precision Marketing** marketers collect and analyze behavioral and transactional data.
- 精准营销人员收集和分析行为和交易数据。



P134

- Permission Marketing 许可营销
- Participatory Marketing 参与式营销
- Customer Empowerment 顾客授权

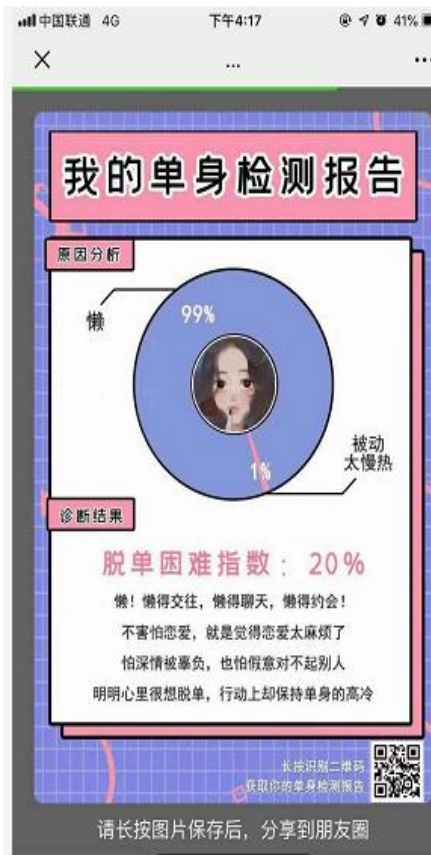
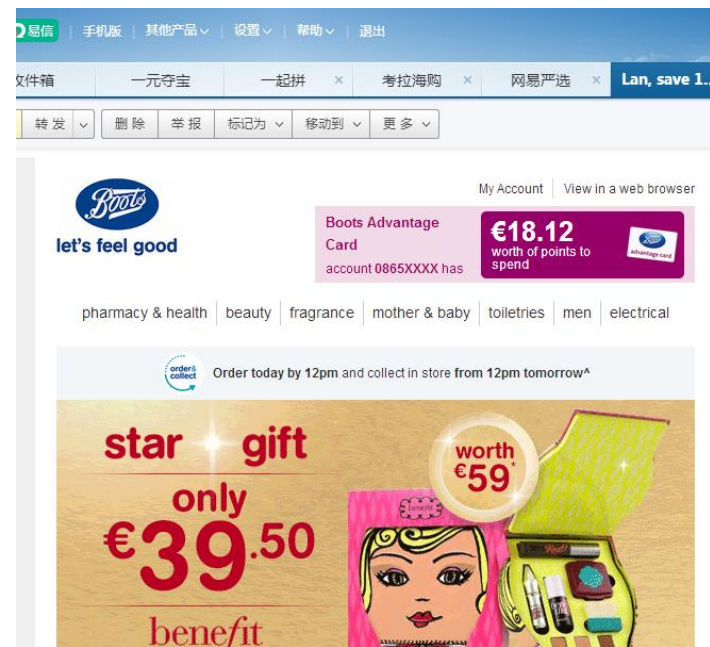

P134

- Buyers Ratings and Referrals
- 顾客评论和推荐





Thanks

Kotler
Keller

4
Analyzing
Consumer Markets
分析消费者市场

Consumer Behavior p142

- Consumer Behavior is the study of how individuals, groups, and organizations select, buy, use and **dispose** of goods, services, ideas, or experiences to satisfy their needs and wants.
- 消费者行为（Consumer behavior）研究的是个人、群体和组织如何挑选、购买使用和处置产品、服务、构思或体验来满足他们的需要和欲望的过程。



What Influences Consumer Behavior?

Cultural Factors

Social Factors

Personal Factors



Social Classes



#劳斯莱斯请晚晚林瀚夫妻...
阅读908.4万 讨论1091 详情>
主持人：新浪汽车

- Social classes, relatively homogeneous and enduring divisions in a society, hierarchically ordered and with members who share similar values, interests, and behavior.
- 社会阶层是在一个社会中具有相对同质性和持久性的群体，他们按等级排列，每一个阶层的成员具有类似的价值观、兴趣爱好和行为方式。



劳斯莱斯汽车
9月24日 12:00 来自 微博视频号
劳斯莱斯库里南西域寻踪，纵行天山之巅，展现出这款豪华汽车的冒险精神，尽享“无处不从容”的人生巅峰。#劳斯莱斯库里南# 劳斯莱斯汽车的微博视频

雷宛莹 (晚晚)
本木美术馆 | 本木艺术社区 创始人
策展人
Wanwan Lei
M WOODS Museum | Art Community Founder
Curator

展开
这次的旅程我们...
0:01/1:25

☆ 收藏 | 1002 | 8086 | 27381



Social Factors

- Reference groups
- Family
- Social roles
- Status

Reference Groups P144

A person's reference groups are all the groups that have a direct(face to face) or indirect influence on their attitudes or behavior.

一个人的参考群体是指直接（面对面）或间接影响他人的看法和行为的群体。

- Primary groups 主要群体
- Secondary groups 次要群体
- Aspirational groups 渴望群体
- Disassociative groups 疏离群体





Fan economy 粉丝经济





- Opinion leader 意见领袖/KOL





Family P145

- Family of orientation consists of parents and siblings.
- 原生家庭包括一个人的双亲和兄弟姐妹。
- Family of procreation --one's spouse and children.
- 再生家庭即夫妻加上子女。



Role and Status P146

- A role consists of the activities a person is expected to perform.
- 角色由一个人应该进行的各项活动组成。
- Each role carries a status.
- 每一种角色都伴随着一种地位。



Personal Factors P146

- Age 年龄
- Life cycle stage 生命周期阶段
- Occupation 职业
- Wealth 财富
- Personality 个性
- Values 价值观
- Lifestyle 生活方式
- Self-concept 自我概念

MUJI 無印良品

Perception 感知/认知P151

- Perception is the process by which we select, organize, and interpret information inputs to create a meaningful picture of the world.

感知/认知是一个人选择、组织并解释接收到的信息，以形成对外部世界有意义的描绘的过程。

- Selective attention 选择性注意
- Selective distortion 选择性扭曲
- Selective retention 选择性保留

Selective attention

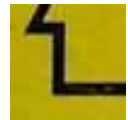

현장별 안내



현장별 안내



关注
273

粉丝
233.2w

获赞
4490.0w

郝凡 优质视频创作者

抖音号: ojbk0220

我是要成为沙雕之王的男人

商务: haofan353

关注

er selective

conjunctic

与需求或兴趣配合

presentation of information is

容或呈现方式奇特

ough. 咨讯强度够大

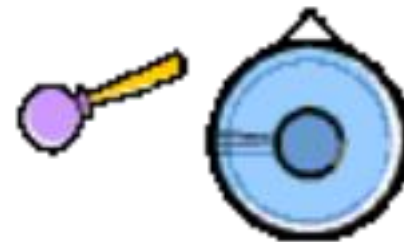

The Buying Decision Process: The Five-Stage Model P156

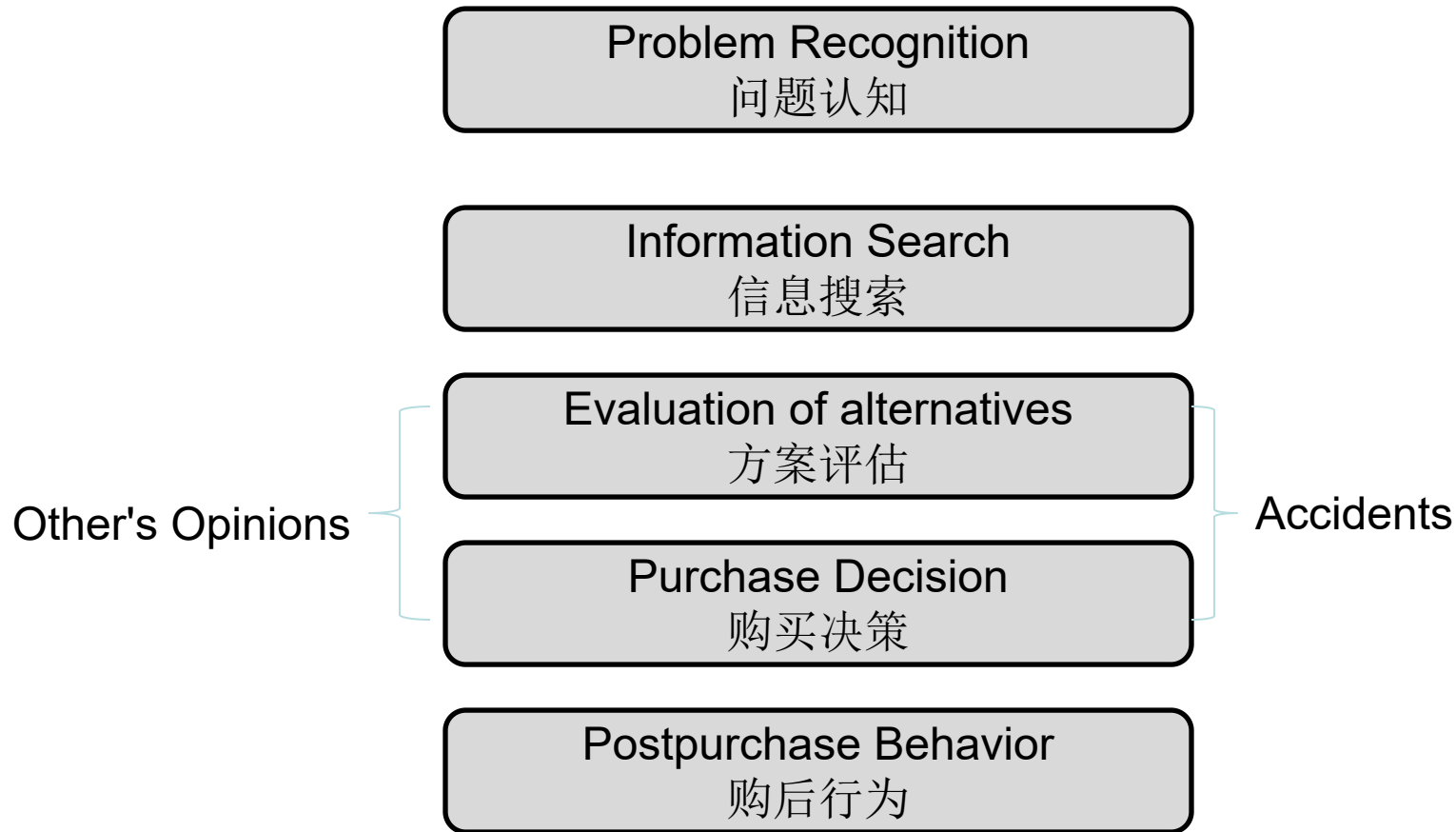



- Thanks.



Kotler
Keller

5

Identifying Market
Segments and Targets
识别细分市场 and 目标市
场

五谷道场——“非油炸，更健康”



Mass Marketing Target Marketing

大众营销 VS 目标营销

- Mass Marketing: Views the market as a single market.
将市场看作单一的市场
- Target Marketing: Recognizes and acts on differences with a market.
识别和对市场之间的差异做出反应。
 - 4Ps are different for different segments.
不同的细分市场4Ps营销策略也不同

What is a Market Segmentation?

什么是市场细分？ P228

- Market segmentation is the process of dividing a market of potential customers into groups, or segments, based on different variables.

市场细分是指根据不同的变量，将潜在客户的市场划分为不同的群体或细分市场的过程。



What is a Market Segment?

什么是细分市场

P228

A **market segment** consists of a group of customers who share a similar set of needs and wants.



一个细分市场
(Market Segment)
由一组具有相似需要
和欲望的消费者组成。

Group Discussion

- Please list at least three category indicators to classify group members.



Segmenting Consumer Markets

细分消费者市场 P229

Geographic

地理

Demographic

人口

Psychographic

心理

Behavioral

行为

Geograph

Geographic re

北方人的冬天
室外冷得像地狱



“外面好冷...我要进屋暖和暖和...”

tier Cities, Four
tier Cities

一线城市5个:

北京 (全国政治、文化、教育中心)

上海 (全国经济中心)

广州 (经济发达, 中国第三大城市)

深圳 (经济发达、特区城市)

天津 (重要经济大港)

一线城市8个:

济发达、副

济发达、副

济发达、副

市, 西部

济发达、计

济发达、计

济发达、计

济发达、计

达城市15

济发展较好、区域中心、副省级省会)

武汉 (经济发展较好、区域中心、副省级省会)

哈尔滨 (经济发展较好、区域中心、副省级省会)

沈阳 (经济发展较好、区域中心、副省级省会)

西安 (区域中心、副省级省会)

长春 (区域中心、副省级省会)

而南方人的冬天
室内才是地狱



“屋里好冷...我要出门暖和暖和...”





Demographic Segmentation

P231

- Age 年齡
 - Life Stage 生活阶段
 - Gender 性别
 - Income 收入
 - Generation 代际/代系
 - Social Class 社会阶层
 - Race and Culture 种族和文化
- 



- Age and Life Cycle

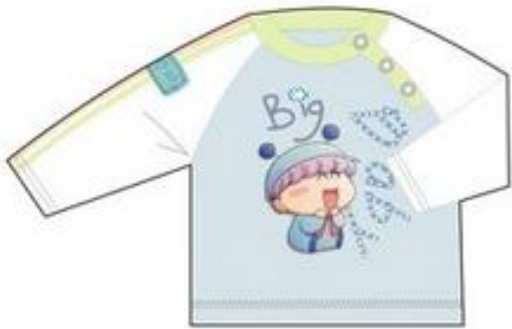



. Gender

京东 热卖
re.jd.com

香水彩妆

美妆 香奈儿香水 口红 指甲油脚趾 美妆工具 彩妆 香水 眼影 化妆品 睫毛膏防水



【关注领券减】尊蓝男士彩妆化妆品套装全套初学者组合化妆品遮瑕痘印BB霜素颜霜护肤品 套餐B自然色

¥ 139.00

去看看

好评度 97%



“你信或者不信，我就在这里，等你来找我~”

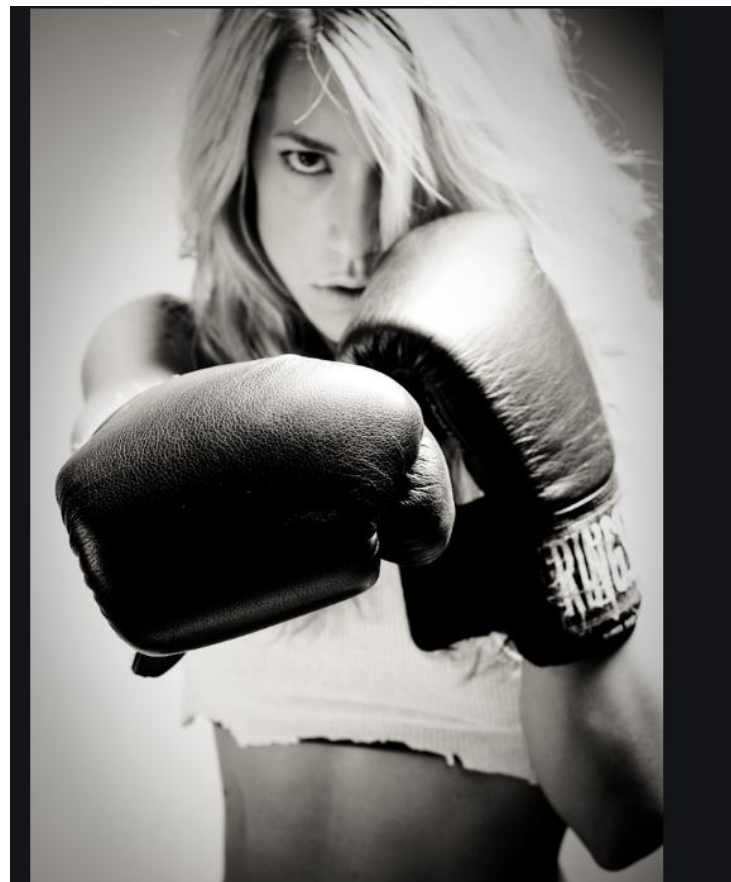

Life Stage(Family Life Cycle)

- Different life stage reflected in the family's income and consumption.
- 不同的生命阶段影响了家庭的收入和消费。



Income and Social Class



- High-end Goods, Normal Goods, Low-end Goods 高档品，中档品，低档品



- Generation
- After 70s,80s, 90s



Psychographic Segmentation (P241)

- Personality 个性
- Life Style 生活方式

MUJI
無印良品



Behavioral Segmentation (P241)

- Occasions时机



Behavioral Segmentation

- Needs and Benefits



Behavioral Segmentation: Decision Roles 决策角色

Initiator 发起者

Influencer 影响者

Decider 决策者

Buyer 购买者

User 使用者



© 视觉中国

Effective Segmentation Criteria (P246)

- Differentiable **可区分** —— 需求差异明显；
- Measurable **可测量** —— 市场规模可测；
- Substantial **足够大** —— 经营有利可图；
- Accessible **可接近** —— 可以有效接近；
(蓝海、红海、黑海)
- Actionable **可操作** —— 企业资源吻合。



What is the Target Market???

- A **target market** is a specific group of consumers at which a company aims its products and services .
- **目标市场（Target Market）**是企业打算进入的细分市场，或打算满足的、具有某一需求的顾客群体。

Evaluating the Market Segments (P246补充)

- Size and Growth 细分市场规模和增长率
- Overall Attractiveness 细分市场的结构吸引力
- Company's Objectives and Resources 企业目标和资源

Market Coverage 市场覆盖模式

P247

- Full Market Coverage 整体市场覆盖化
 - Through differentiated or undifferentiated marketing.
通过差异化或者无差异化营销
- Multiple Segment Specialization 多元细分市场专业化
 - Selective Specialization 选择性专业化
 - Product Specialization 产品专业化
 - Market Specialization 市场专业化
- Single-Segment Concentration 单一市场集中化
 - Market Leader Strategy 领导者战略
 - Market Challenger Strategy 挑战者战略
 - Follower Strategy 跟随者战略
 - Niche strategy 利基者战略



Full Market Coverage



P1			
P2			
P3			
	M1	M2	M3

Undifferentiated 无差异营销

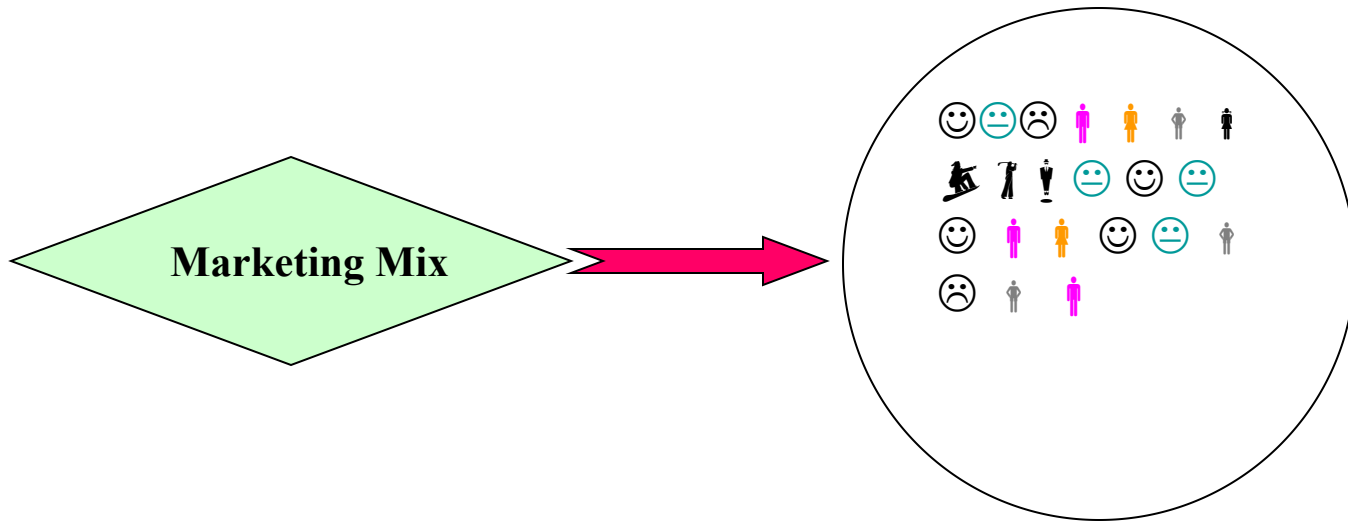

Differentiated 差异营销

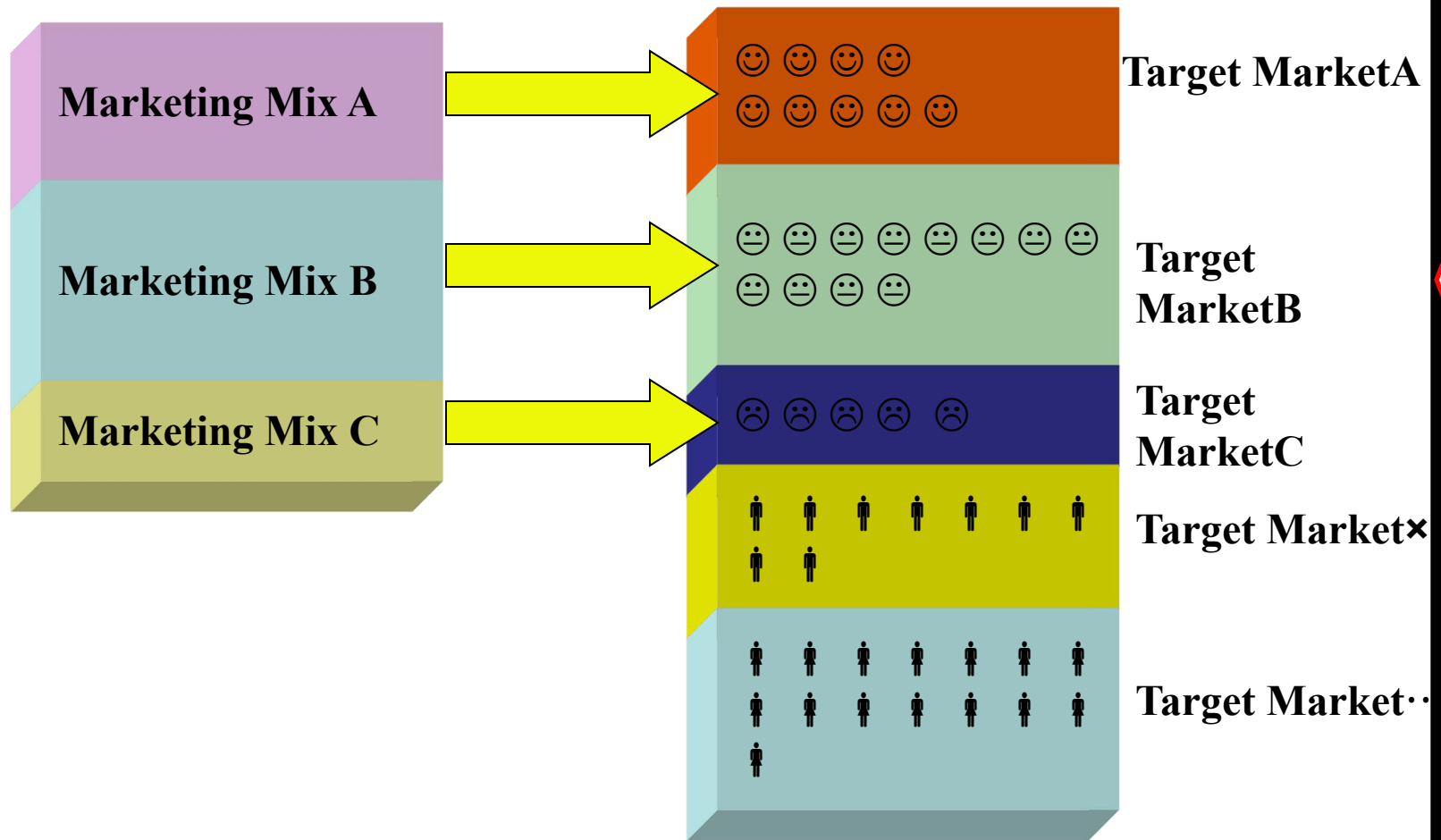



Selective Specialization

P1			
P2			
P3			
	M1	M2	M3

Product Specialization

P1			
P2			
P3			
	M1	M2	M3

留学机构, 留学机构哪家好? 北京专业留学机构



留学机构, 津桥留学专注留学24年, 提供专业留学服务. 留学机构, 多对一留学咨询, 各种背景提升项目, 一站式留学服务.

美国留学 - 英国留学 - 澳洲留学 - 加拿大留学 - 新西兰留学 - 香港求学

www.oxbridgetu.org - 2020-04-15 广告 [在线客服](#)



美国留学
多对一咨询



英国留学
高端背景提升



澳洲留学
专业文书写作



加拿大留学
留学面试指南

Market Specialization

P1			
P2			
P3			
	M1	M2	M3



Single-Segment Concentration

P1			
P2			
P3			
	M1	M2	M3





- Thank you!



Kotler
Keller

6
Crafting the
Brand Positioning
确定品牌定位

Zbird 钻石小鸟



What is Positioning?

什么是定位？ P257

- Positioning is the act of designing a company's offering and image to occupy a **distinctive** place in the minds of the **target market**.
- 定位 (positioning)** 是设计公司的产品和形象以在目标顾客心目中占据一个**独特**位置的行动。



人海茫茫，不过我还是一眼就发现了你

Deciding on a positioning requires: 定位决策需要?

- (1) Determining a frame of reference by identifying the target market and relevant competition. P258
- 通过识别目标市场和相关竞争状况确定竞争性参考框架

Target Market Description

目标消费者描述

- **Head & Shoulders 海飞丝**
 - Shampoo users with dandruff.
有头皮屑问题的洗发精使用者
- **Nescafe雀巢咖啡**
 - The tasty white-collar.
讲求生活品味的白领阶层
- **Nestle Infant Formula 雀巢儿童奶粉**
 - The mother who care about the growth of children aged 1 to 12. 关心1岁~12岁小孩成长的妈妈

Behavioral Segmentation: Decision Roles 决策角色（补充）

Initiator 发起者

Influencer 影响者

Decider 决策者

Buyer 购买者

User 使用者



© 视觉中国

Don't let your child cry for washing his/her hair.

别让孩子为洗头而哭泣

- **Mild Shampoo**
- 温和的洗发精



Johnson & Johnson

Identifying Competitors

识别竞争对手

- Determine category membership

确定品类成员

—the products or sets of products with which a brand competes and which function as close substitutes.

品牌与之竞争的产品或产品集合，或者功能与之相近的替代品。





The type of Competitor

竞争对手类型

- Strong and Weak Competitors
强竞争者与弱竞争者
- Close and Distance Competitors
近竞争者与远竞争者
- Well-behaved and Disruptive Competitors
“良性”与“恶性”竞争者

Group Discussionong



Analyzing Competitors

分析竞争对手P259

表 10.2 顾客对竞争者关键成功因素的评级

	知晓度	产品质量	产品可得性	技术支持	销售团队
竞争者 A	E	E	P	P	G
竞争者 B	G	G	E	G	E
竞争者 C	F	P	G	F	F

注：E=优秀 (excellent)；G=良好 (good)；F=一般 (fair)；P=差 (poor)。

Deciding on a positioning requires:

- (2) Identifying the optimal points of parity and points of difference brand associations given.

识别品牌联想给予的最佳的差异点和共同点

Points-of-difference (PODs) (P310)

- Points-of-difference (PODs) are attributes or benefits that consumers strongly associate with a brand, positively evaluate, and believe they could not find to the same extent with a competitive brand.
- 差异点是消费者强烈地联想到的品牌属性或利益，消费者给予正面评价，并相信不能同样程度地从竞争品牌中找到这样的品牌属性或利益。
-



- ✓ Volvo: Safety
- ✓ Federal Express: Overnight
- ✓ Crest: No decayed tooth

- 沃尔沃：“安全”
- 联邦快递：“隔天到”
- 佳洁士：“没有蛀牙”



“Lee”

- Target Market: Female who is from 25 to 44.
- 目标市场：25-44岁的女性

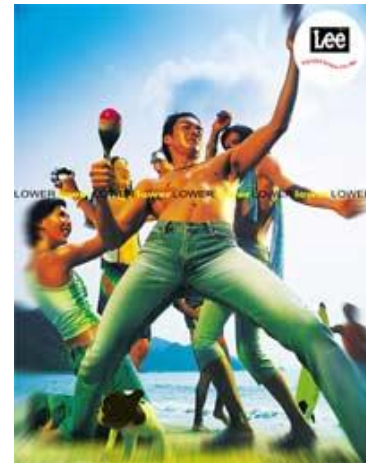
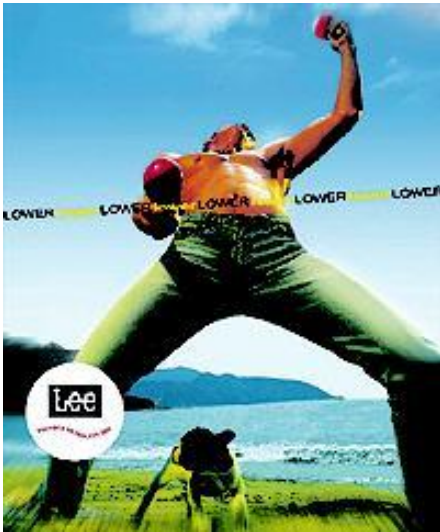

Points-of-parity (POPs) (P311)共同点

- Points-of-parity (POPs), on the other hand, are attribute or benefit associations that are not necessarily unique to the brand but may in fact be shared with other brands.

共同点是那些对品牌来说并非独特，实际上可能与其他品牌共享的一些属性或利益联想。

- These types of associations come in two basic forms: category and competitive.

这些联想有两种基本形式：品类联想和竞争性联想。



The way to positioning. 市场定位的方式

- Avoid the strong positioning. 避强定位
- Competitive positioning. 迎头定位
- Repositioning. 重新定位





Mar

- Cre
- Targ





- The brand repositioning happened in the 1954.
- “Man always remember lovely, because of romantic only” → Marlboro
男人总是忘不了女人的爱



- Slogan: “where there is a man, there is a Marlboro”
- Cowboy+ Score

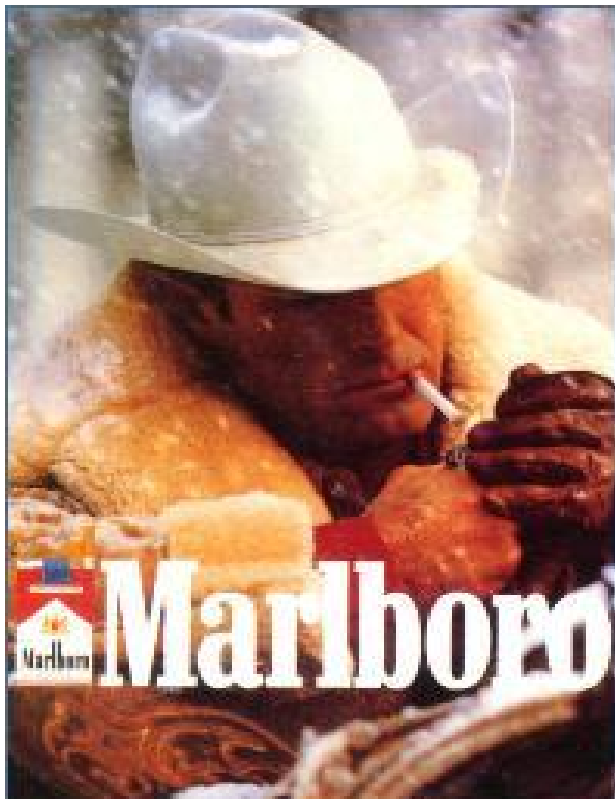

Positioning Strategy

定位战略

- Special Elements
- 特色成分定位



Evian

Evian



- The positioning of Evian: Spring water with healthy and pure. 健康纯净的矿泉水





- Features特色功能定位



Breath-Shoes

- Specific User特定使用者定位





SHES VERY CHARLIE.

REVLON

图 8.16 1988 年为瑞夫浓公司的查利牌香水所作的广告, 描画了一位信心十足、独立自主的女性。



- Emotional情感定位



- The First Position 第一定位







- Thank you!

Kotler
Keller

7

Setting Product Strategy

制定产品策略



4Ps--营销策略组合

- Product产品: Creating Value创造价值
- Price价格: Reflecting Value体现价值
- Place 渠道: Delivering Value交付价值
- Promotion促销 :Communicating Value传播价值

Product Levels 产品层次

The Customer-Value Hierarchy

顾客价值层级

- Do you know what is a product???



What is a Product?P342

A **product** is anything that can be offered to a market to satisfy a want or need, including physical goods, services, experiences, events, persons, places, properties, organizations, information, and ideas.

产品是任何一种能被提供给市场以满足需要或欲望的东西，包括有形物品、服务、体验、事件、人物、地点、财产、组织、信息和想法等。

Why do you buy lipsticks?



Figure 13.2 Five Product Levels

五个产品层次 P342

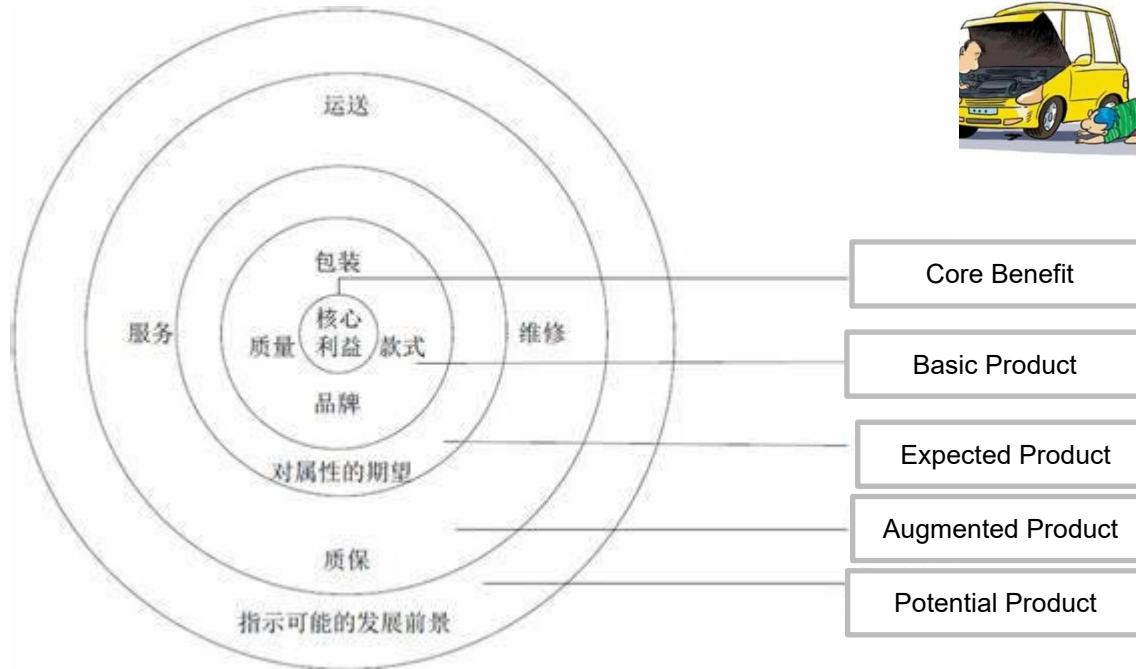

- Core Benefit
- Basic Product
- Expected Product
- Augmented Product
- Potential Product





Group Discussion

- Choose a product to analyze the five product level.



Product MixP354

产品组合

- A product mix (also called a product assortment) is the set of all products and items a particular seller offers for sale.

产品组合（Product mix）是卖方提供出售的所有产品和品目的集合。

- Product line**产品线**:
- A group of related products manufactured by a single company.

产品线（product lines）是指产品组合中的某一产品大类，是一组密切相关的产品。



- The width of a product mix.
产品组合的宽度
- The length of a product mix.
产品组合的长度
- The depth of a product mix.
产品组合的深度
- The consistency of the product mix.
产品组合的紧密度

耿丹学院产品组合

国际商学院	信息工程学院	机电工程学院	人文学院	国际设计学院
市场营销	计算机科学与技术	机械制造	应用心理学	视觉传达
财务管理	物联网	建筑学	国际汉语言	产品设计
国际经济与贸易	数字媒体技术	城乡规划	社会工作	环境设计
金融工程	通信工程	工业设计		戏剧与美术
	电子信息	工程管理		数字媒体艺术
				动画

Product-Line Analysis

产品线分析

- Sales and Profits
- 销售额和利润

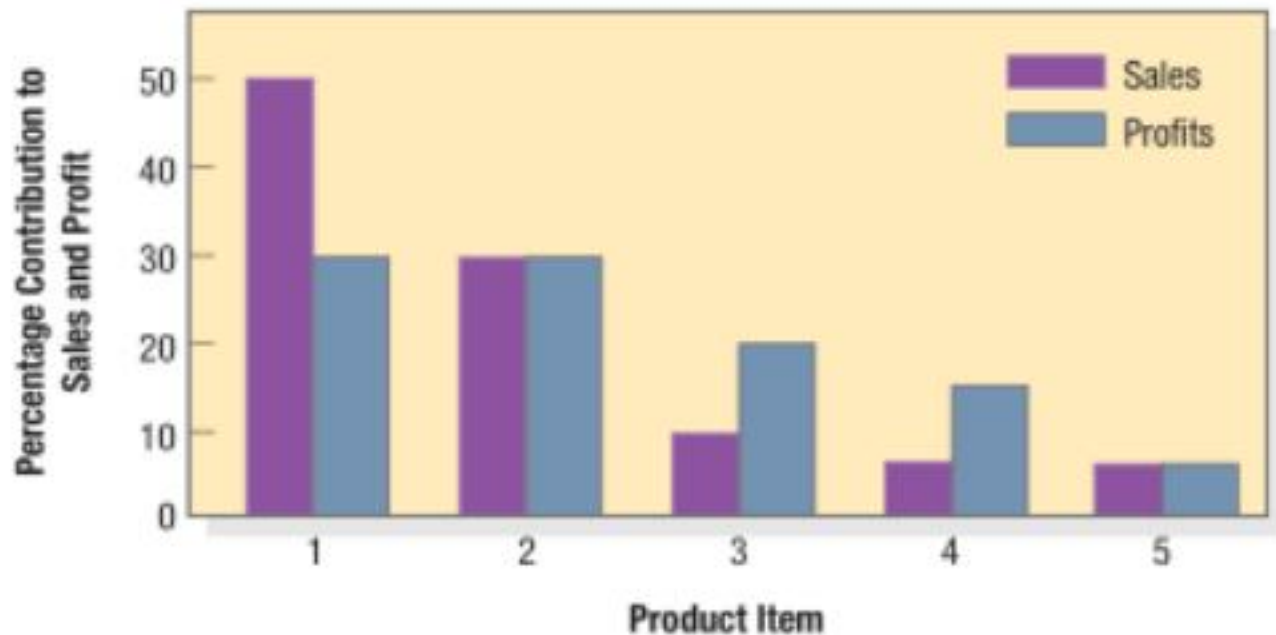

BCG Matrix

波士顿矩阵

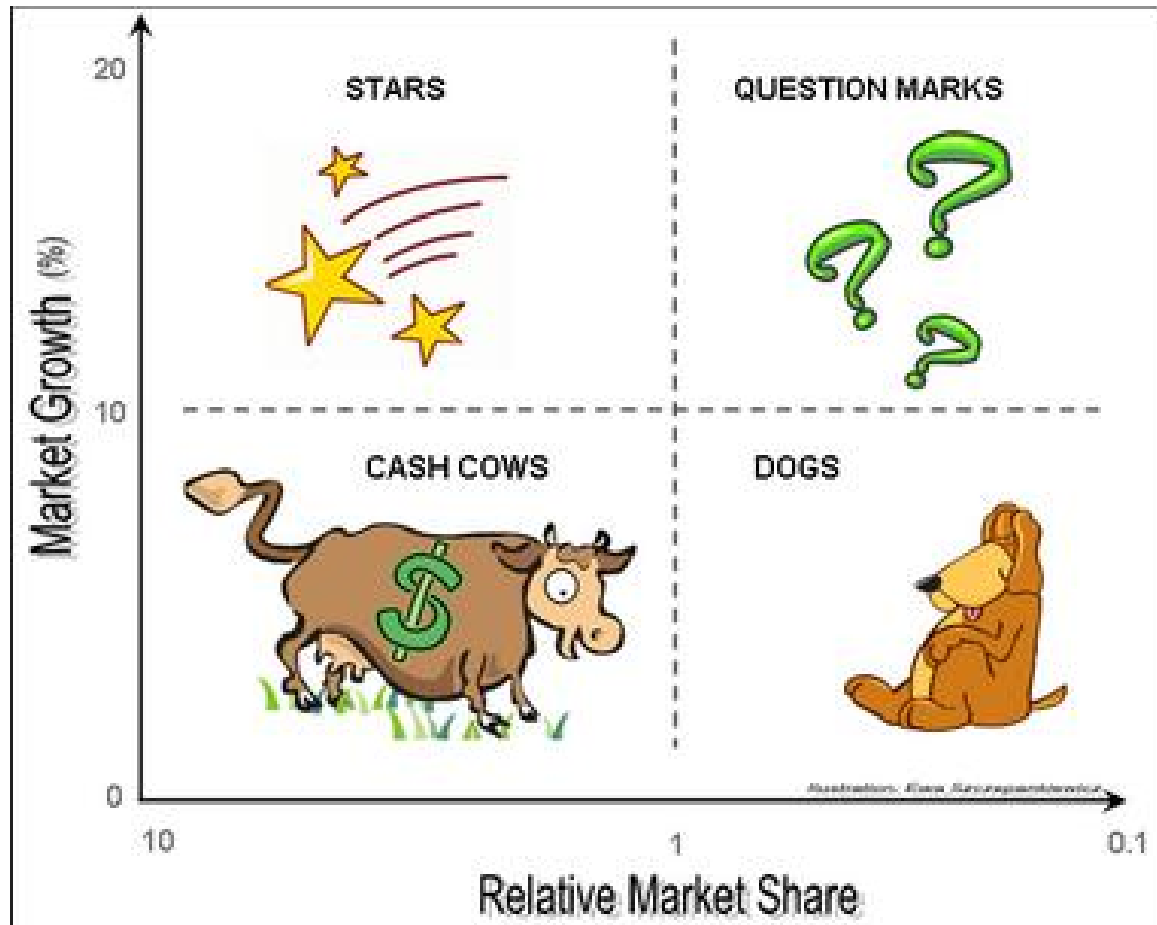



lenovo 联想

IBM®

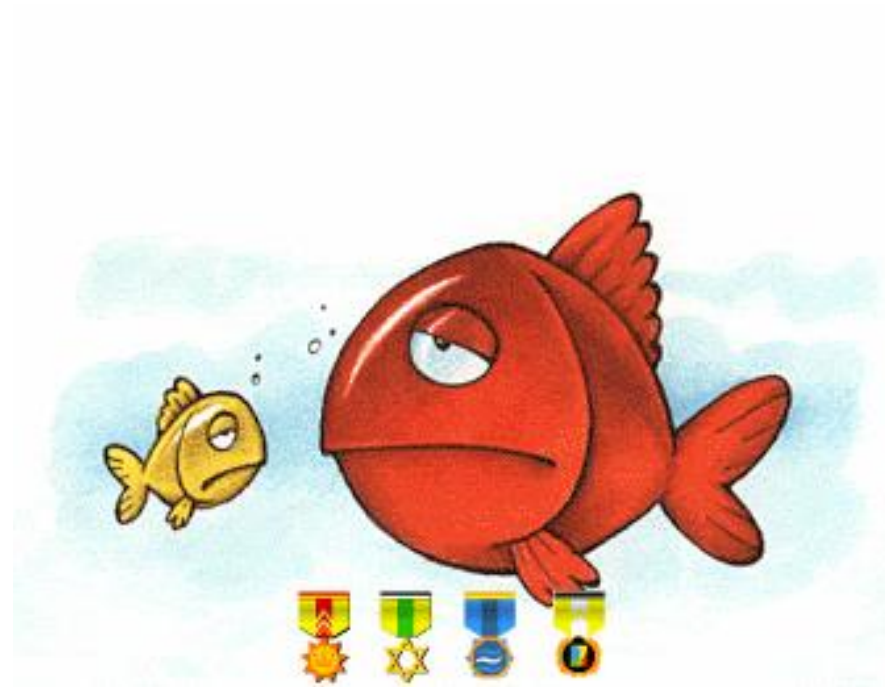

Product Mix Decision

产品组合决策 P357

- Line Stretching 产品线拓展 增加产品线的宽度
 - Down-Market Stretch
 - Up-Market Stretch
 - Two-Way Stretch
- Line Filling 产品线填补 增加产品线的长度
- Line Pruning 产品线削减 减少产品线的长度、宽度
- Line Updating and Featuring 产品线更新和特色化

Product Life Cycle

P325 产品生命周期

- Product have a limited life.
- Introduction 导入期
- Growth 成长期
- Maturity 成熟期
- Decline 衰退期

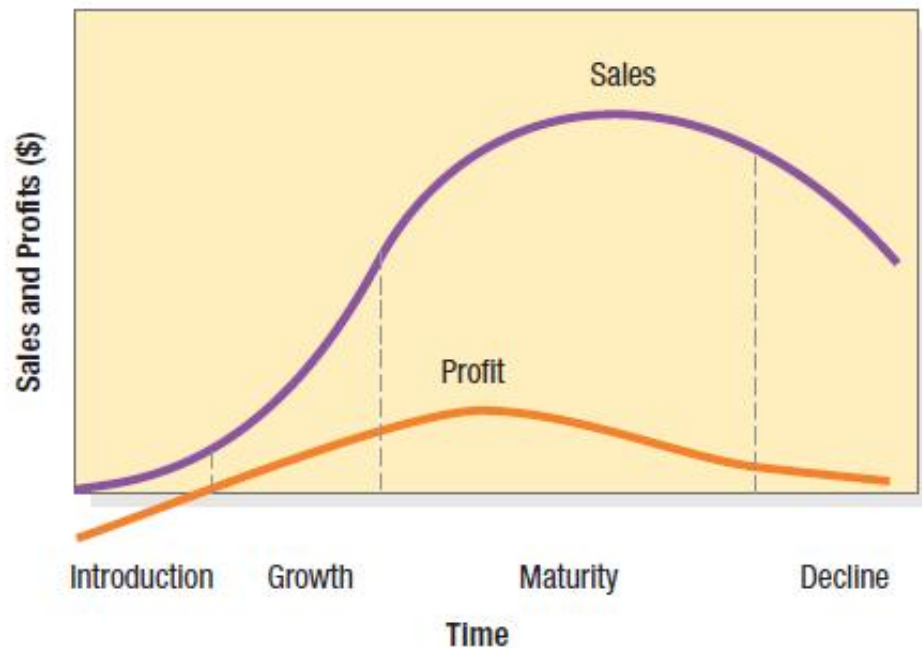

Figure 13.5a

Common PLC Patterns:

Growth-Slump-Maturity

普通商品的生命周期模式:

成长-下降-成熟

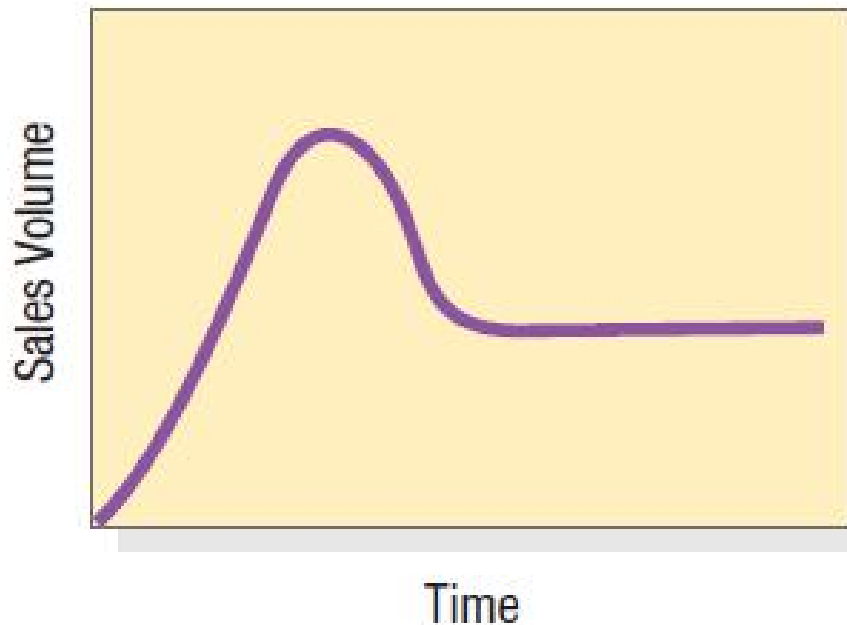

Figure 13.5b

Common PLC Patterns:

Cycle-Recycle

普通商品的生命周期模式:

循环-再循环

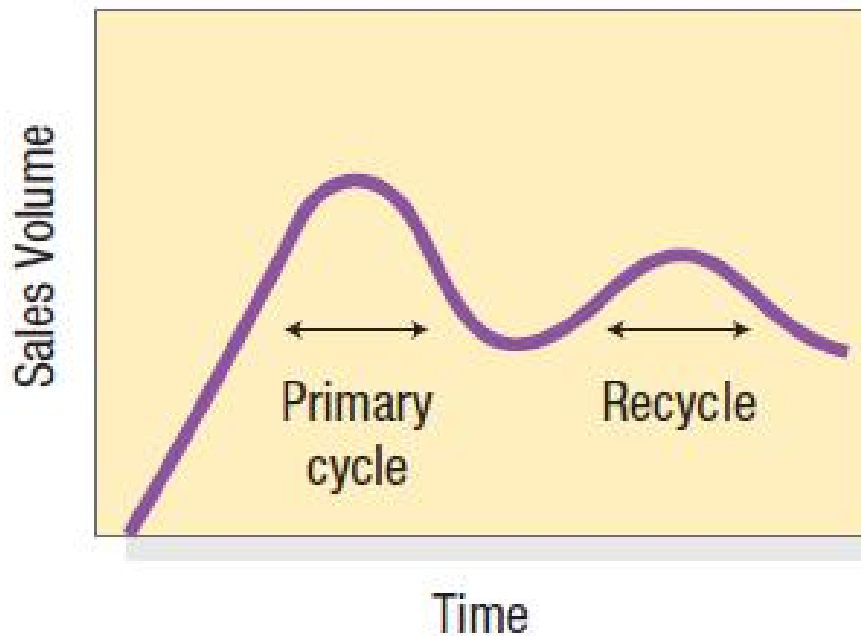

Figure 13.5c

Common PLC Patterns:

Scalloped

普通商品的生命周期模式：
扇形模式

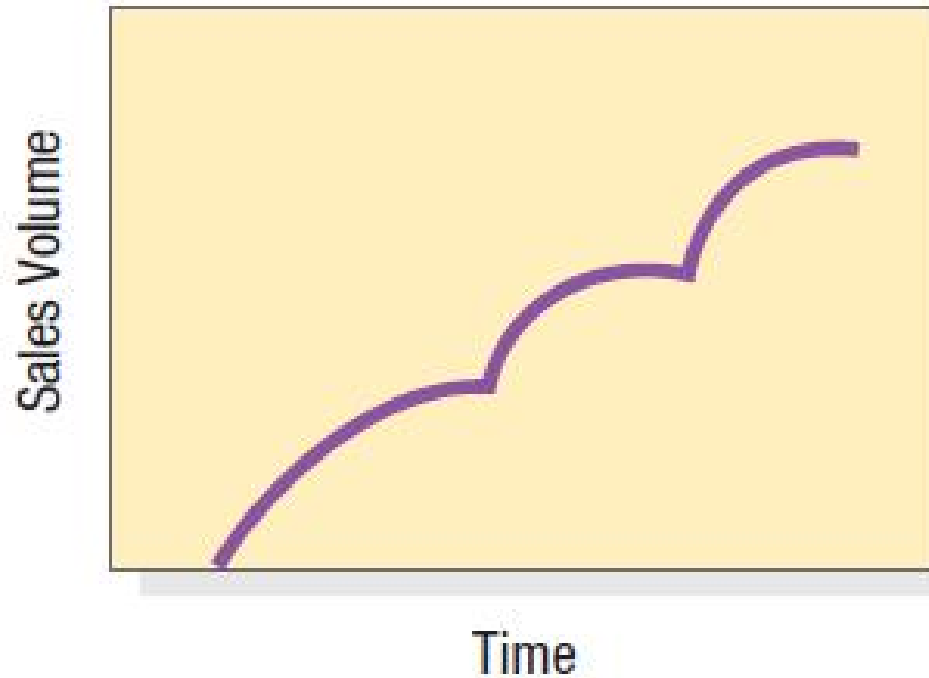

Figure 13.6 Style, Fashion, and Fad Life Cycles

风格、流行和时尚的生命周期



Introduction Stage Strategies

导入期策略

Marketing Features 市场特征:

- Low sales, high costs. 低销量、高成本
- Less profit. 利润少
- It's hard to do price strategy. 很难做价格决策
- High risk. 高风险

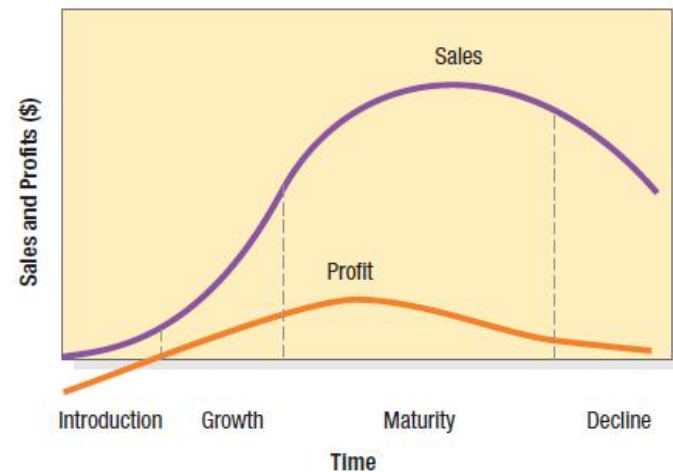

Introduction Stage Strategies

导入期策略

- Identifying market demands.
识别市场需求
- Choosing the right time.
选择合适的时机
- Understanding consumer behavior.
了解消费者行为



Growth Stage Strategies

成长期策略

Marketing Features 市场特征:

- Companies begin to obtain profit.

企业开始获利

- A rapid climb in sales.

销量迅速增长

- New competitors enter.

新的竞争者进入



Growth Stage Strategies

成长期策略

- Improving your product's quality and features.
提高产品的质量和性能
- Expansion of distribution lines
扩张分销渠道
- Reach to the new customers profile.
进入新的细分市场



Maturity Stage Strategies

成熟期策略

- Growth Maturity 成长成熟期
- Stable Maturity 稳定成熟期
- Decaying Maturity 衰退成熟期

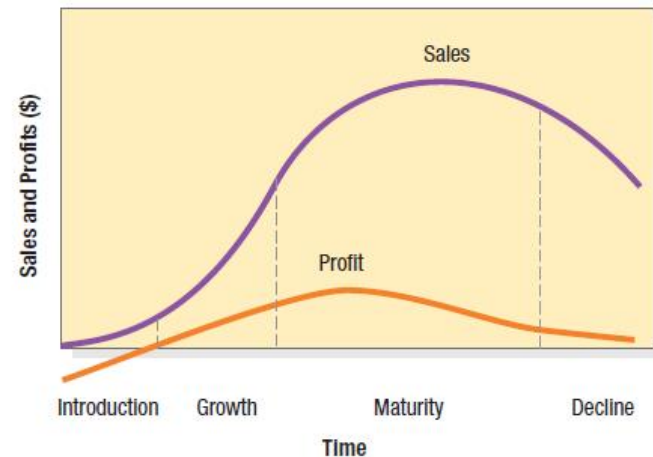

Maturity Stage Strategies

成熟期策略

- Market Modification 市场调整
- Product Modification 产品调整
 - ✓ Quality Improvement 质量改良
 - ✓ Feature Improvement 特色改进
 - ✓ Style Improvement 风格改进
- Marketing Program Modification
营销方案的调整 Price/Place/Promotion

Decline Stage Strategies

衰退期策略

Marketing Features 市场特征

- the rate of sales reduces visibly

销量急剧下降

Strategy 策略

- Harvest 收获
- Divest 剥夺

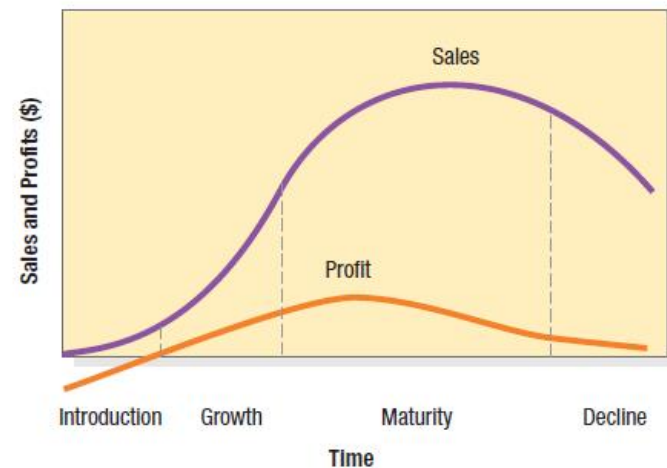



- Thanks

Kotler
Keller

8

**Developing Pricing
Strategies and Programs**
制定价格策略和方案

Understanding Pricing 理解定价 P432

- Rent租金
- Tuition学费
- Fares交通费
- Fees公共事业费
- Rates费率
- Tolls通行费
- Wages工资
- Commissions佣金
-

中新网 图片频道
北京公交地铁调价听证方案

地铁调价方案

方案一	方案二
起步3公里内每人2元 3-6公里每人3元 6-10公里每人4元 10-12公里每人5元 12-22公里每人6元 22公里以上每20公里加1元 票价不封顶	起步6公里内每人3元 6-12公里每人4元 12-32公里每人5元 32公里以上每20公里加1元 票价不封顶

方案一

0-3公里	3-6公里	6-12公里
2元	3元	4元

方案二

0-6公里	6-12公里	12-22公里	22-32公里	32-52公里
3元	4元	5元	6元	7元

优惠政策

每自然月内，乘客乘车使用市政交通一卡通支出累计满100元后，超出部分给予8折优惠；满150元后，超出部分给予5折优惠；支出累计达到400元后，不再享受打折优惠。

例：张三从八通线梨园站到大兴线磁窑厂站，距离18公里，票价5元。每天乘坐2次，每月乘坐22次。
当月第21次乘车时，票价开始享受折扣优惠，即4元。
第20次乘车时，票价开始享受5折优惠，即2.5元。
一个月下来，张三乘车共44次，票价共178元，平均每次4元。调价前每多9元。

地铁调价方案对比

方案一	方案二
起步价与现行票价水平相衔接 加价计费里程比较精细 有4.35%的乘客不受调价影响 中长途乘客费用相对较高 平均票价为每人4.4元	适当提高起步价格 加价计费里程较为简单 约11%的人群调价幅度低于方案一 对长途乘客相对有利 平均票价为每人4.3元

公交调价方案

方案一	方案二
起步5公里内每人1元 以后每增加10公里加价1元 取消一卡通普通卡刷卡优惠 学生卡刷卡5折优惠	起步10公里内每人2元 以后每增加5公里加价1元 一卡通普通卡刷卡实行5折优惠 学生卡刷卡实行2.5折优惠

方案一

0-5公里	5-15公里
1元	2元

方案二

0-10公里	10-15公里	15-20公里	20-25公里	25-30公里	30-35公里
2元/1元	3元/1.5元	4元/2元	5元/2.5元	6元/3元	7元/3.5元

例：张三乘车10公里，方案一票价3元，方案二扣现金票价4元，如用一卡通票价2元。

公交调价方案对比

方案一	方案二
取消折扣优惠 对使用现金购票的人群影响较小 平均票价为每人1.85元	适当提高票价 继续给予刷卡优惠 平均票价为每人1.31元

资料来源：北京市发展和改革委员会 设计：任列

Steps in Setting Price

制定定价的步骤P438

- Selecting the Pricing Objective 选择定价目标
- Determining Demand 确定需求
- Estimating Costs 估计成本
- **Analyzing Government's Policies and Decrees**
分析政府的政策法规
- Analyzing Competitor's Costs, Prices and Offers 分析竞争者的成本、价格和产品
- Selecting a Pricing Method 选择一种定价方法
- Selecting the Final Price 最终确定价格

Steps in Setting Price

制定定价的步骤P438

- Selecting the Pricing Objective 选择定价目标
- Determining Demand 确定需求
- Estimating Costs 估计成本
- **Analyzing Government's Policies and Decrees**
分析政府的政策法规
- Analyzing Competitor's Costs, Prices and Offers 分析竞争者的成本、价格和产品
- Selecting a Pricing Method 选择一种定价方法
- Selecting the Final Price 最终确定价格

Step 1: Selecting the Pricing Objective

选择定价目标 P438

- Survival生存
- Maximum current profit(Price elasticity of demand)当前的利润最大化 (需求的价格弹性)
指企业通过特定水平的价格制定或调整所要达到的预期目的
- Maximum market share市场份额最大化
- Maximum market skimming当前利润最大化
- Product-quality leadership产品-质量领导地位
- Other pricing objectives其他定价目标

Step 2: Determining Demand

确定需求 P441

- Price sensitivity 价格敏感性
- Estimate demand curves 估计需求曲线
- Price elasticity of demand 需求价格弹性

Figure Inelastic and

Elastic Demand 缺乏弹性需求和富有弹性需求

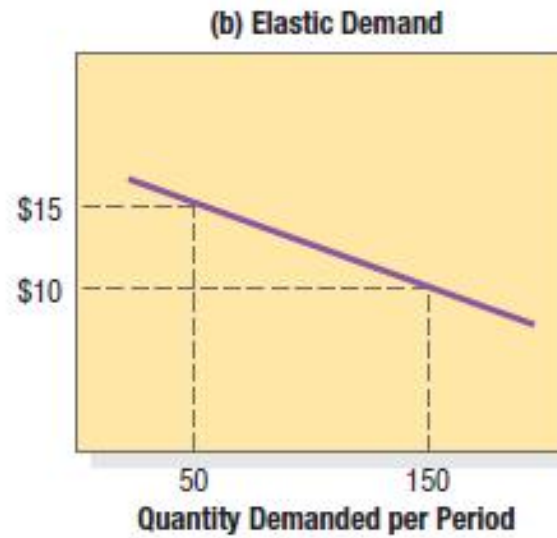

Step 3: Estimating Costs

估计成本

- Types of costs 成本的类型
 - ✓ Total costs 总成本
 - ✓ Fixed costs 固定成本
 - ✓ Variable costs 可变成本
 - ✓ Average cost 平均成本

Economies of scale 规模经济

Diseconomies of scale 规模不经济

Step 4: Analyzing Government's Policies and Decrees

分析政府的政策法令

- Limit order 限价令
- Anti-Dumping 反倾销
- Anti-Subsidy 反补贴



Ste Cos 者自

· FIG Pri 价相



zing Co and Of 格和产占

e Three C 型

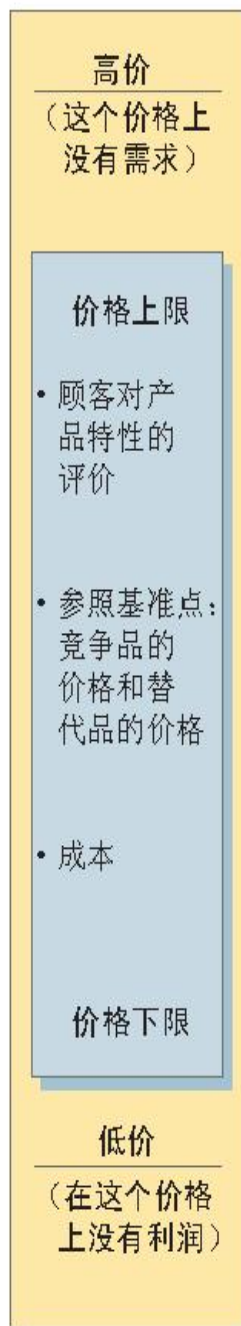

tor's 析竞争

for

Step 6: Selecting a Pricing Method

选择定价方法

- Markup pricing 加成定价法
- Add a standard markup to the product's cost.
对产品成本进行一个标准的加成

$$P = (C / Q + VC) \times (1 + r)$$

- Add a standard markup to sales.
对销售额进行一个标准的加成

$$P = \frac{C + VC \times Q}{(1 - r)Q}$$

Figure 14.5 Break-Even Chart for Determining Target-Return Price and Break-Even Volume: 确定目标收益价格和盈亏平衡销量

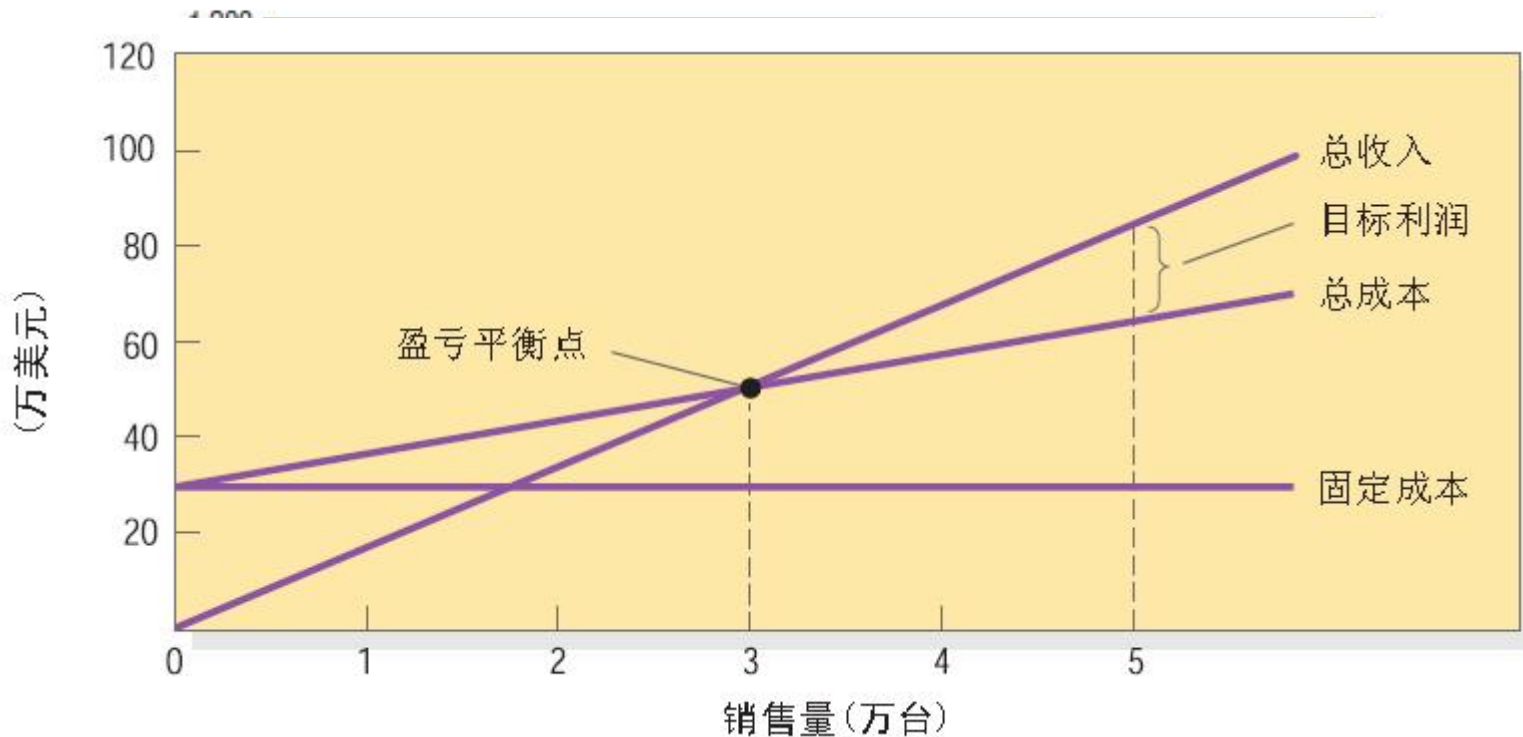



新品 Apple iPhone 13 Pro (A2639) 128GB 远峰蓝色 支持移动联通电信5G 双卡双待手机

选购[1年AC+版]限时抢服务2折券, 放心用机, 无惧意外! 选购[快充套装]加9元得20W快充头! 更多优惠! [查看>](#)

京东价 **¥7999.00** 降价通知

累计评价
20万+

增值业务 [高价回收, 极速到账](#)

配送至 [北京东城区北新桥街道](#) 采购中, 预计2021-12-26日后有货
支持 [可配送港澳台](#) | [99元免基础运费](#) | [免举证退换货](#) | [自提](#)

由 [京东](#) 发货, 并提供售后服务.

重量 0.36kg

选择颜色 [远峰蓝色](#) [石墨色](#) [银色](#) [金色](#)

选择版本 [128GB](#) [256GB](#) [512GB](#) [1TB](#)

购买方式 [公开版](#) [【1年AC+版商详领券购买!】](#) [快充套装](#) [AirPods套装](#)

套 装 [优惠套装1](#) [优惠套装2](#) [优惠套装3](#) [优惠套装4](#) [优惠套装5](#) [优惠套装6](#)

原厂服务 [原厂电池换新 ¥359.00](#) [官方AC+ ¥848.00](#)

增值保障 [2年碎屏保修 ¥379.00](#) [2年全保修+ ¥399.00](#) [2年电池换新 ¥69.00](#)

京东服务 [黑科技充电宝 ¥129.00](#)

白条分期 [不分期](#) [¥2706.34 x 3期](#) [¥1373.15 x 6期](#) [¥706.62 x 12期](#) [¥373.33 x 24期](#)

1 **加入购物车**



易调
中的
角的

关注 分享 对比 举报

企业购更优惠

- Value pricing价值定价法
- Companies that adopt value pricing win loyal customers by charging a fairly low price for a high-quality offering.
- 通过低价提供高质量的产品或服务赢得忠实顾客。





- Going-rate pricing 随行就市定价法



- Auction-type pricing(English Auction , Dutch Auction, Sealed-bid Auctions)拍卖定价法

Consumer Psychology and Pricing 消费者心理和定价

- Reference prices 参考价格
- Price-quality inferences 价格-质量推断
- Price endings 价格尾数

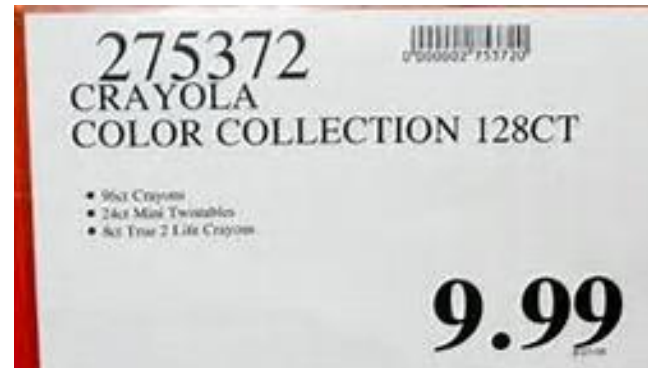

Step 7: Selecting the Final Price

制定最终价格

- Impact of other marketing activities
其他营销活动的影响
- Company pricing policies
公司定价政策
- Gain-and-risk sharing pricing
收益-风险分担定价
- Impact of price on other parties
价格对其他各方的影响

Geographical Pricing 地理定价策略

- Pricing varies by location



Price Discounts and Allowances 折扣和折让

- Discount折扣
- Quantity discount数量折扣
- Functional discount职能折扣
- Seasonal discount季节折扣
- Allowance折让



Promotional Pricing Tactics

促销定价

- Loss-leader pricing 亏本出售定价法
- Special-event pricing 特殊事件定价法
- Cash rebates 现金回扣
- Low-interest financing 低息贷款
- Longer payment terms 较长付款期限
- Warranties and service contracts 担保和服务合同
- Psychological discounting 心理折扣

Differentiated Pricing

差别定价

- Customer-segment pricing 顾客细分市场定价
- Product-form pricing 产品样式定价
- Image pricing 形象定价
- Channel pricing 渠道定价
- Location pricing 位置定价
- Time pricing 时间定价
- Yield pricing 收益定价

Product-Mix Pricing

产品组合定价 P361-362

- Product-line pricing 产品线定价
- Optional-feature pricing 选择品定价
- Captive-product pricing 附属产品定价
- Two-part pricing 两部分定价
- By-product pricing 副产品定价
- Product-bundling pricing (pure bundling, mixed bundling) 产品捆绑定价——完全捆绑、混合捆绑



- Thanks.



9

Designing and Managing Integrated Marketing Channels



设计和管理整合营销渠道

What is a Marketing Channel?

P464 什么是营销渠道

A **marketing channel** system is the particular set of interdependent organizations involved in the process of making a product or service available for use or consumption.

□ **营销渠道 (Marketing channels)**，是促使产品或服务顺利地被使用或消费的一整套相互依存的组织。

- 
- **Merchants**（买卖中间商）--批发商、零售商
 - **Agents**（代理商）--经纪人、制造商代理商、销售代理人
 - **Facilitators**（辅助机构）--运输公司、独立仓库、银行、广告代理商
- 

Marketing Channel System

营销渠道系统

MICHAEL KORS(赛特奥莱店) 手机买单 积分抵现

★★★★★ 123 条评论 消费: 1596元 产品: 8.9 环境: 9.0 服务: 8.7

地址: 香江北路28号赛特奥莱1楼064号 

电话: 010-842960** [登录显示完整信息] [登录显示完整信息]

更多信息 

TMALL天猫

MICHAEL KORS官方旗舰店
品牌直销 

描述 服务 物流
4.8↓ 4.8↑ 4.8↑

手机逛

搜索 天猫 商品/品牌/店铺

搜天猫

搜本店

MICHAEL KORS

女士

男士

手袋

服饰

鞋履

配饰

优惠

Push and Pull Strategy 465

推进
策略



拉动
策略

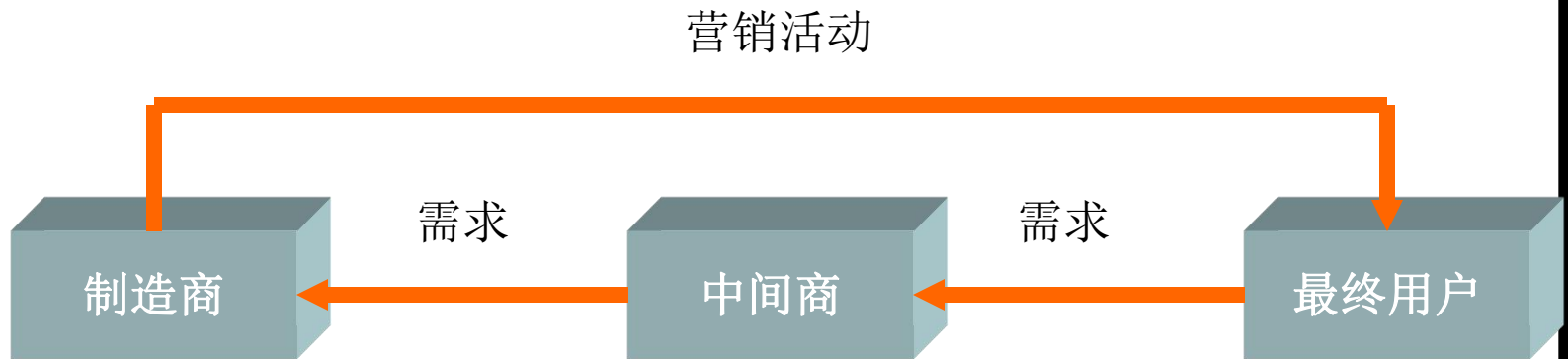



Multichannel Marketing P465

- Multichannel marketing, using two or more marketing channels to reach customer segments in one market area.
- 多渠道营销，即在某一市场领域中，采用两种或两种以上得营销渠道接近客户群体。

Omnichannel Marketing全渠道营销

P466

- Omnichannel marketing, in which multiple channels work seamlessly together and match each target customer's preferred ways of doing business, delivering the right product information and customer service regardless of whether customers are online, in the store, or on the phone.
- 全渠道营销意味着多种渠道无缝连接，相互协作，并且符合每个目标顾客偏好的购物、传递正确的商品信息和提供客户服务的方式，而无需考虑顾客是在网上、店里还是电话那头。

小米全渠道营销案例



全渠道零售

体验式

注重顾客的购物体验以及之后反馈。
应让用户成为品牌倡导者。

交易性

顾客支付和接收购买产品或服务的途径应简单、透明且快捷。

信息化

顾客如何了解你的品牌，产品和服务。
帮助用户发现他们一直寻找的产品。

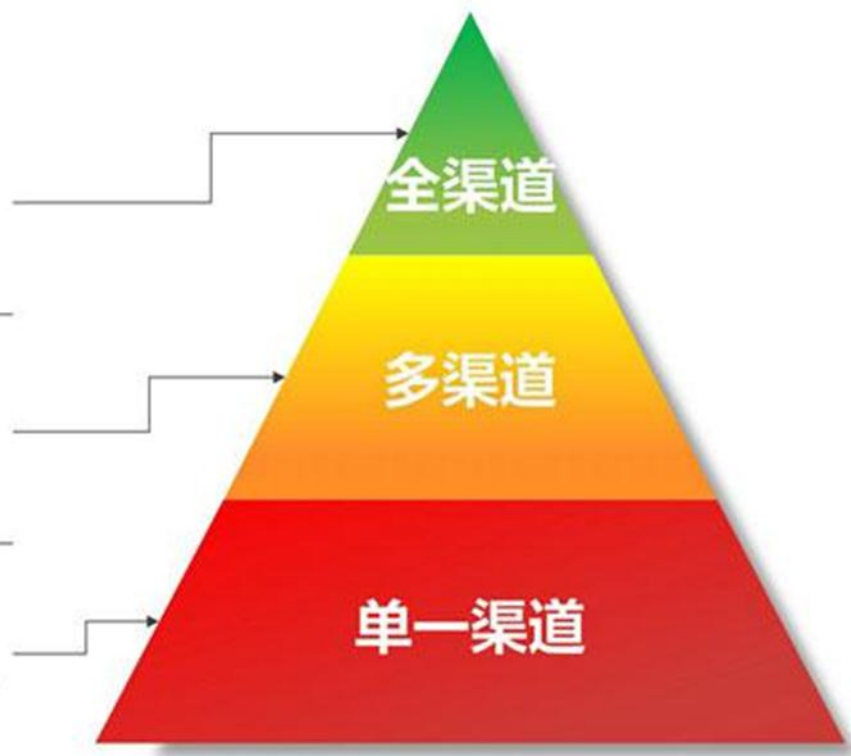

Integrated Marketing Channel System 整合营销渠道系统 P466

- Integrated marketing channel system, the strategies and tactics of selling through one channel reflect the strategies and tactics of selling through one or more other channels.
- 整合营销渠道系统是指在这样一个系统中，任一渠道销售的战略战术都体现着其他渠道的销售战略战术。

Marketing Channel Levels

渠道层级 P471

Consumer Markets 消费者市场

(a) Consumer Marketing Channels

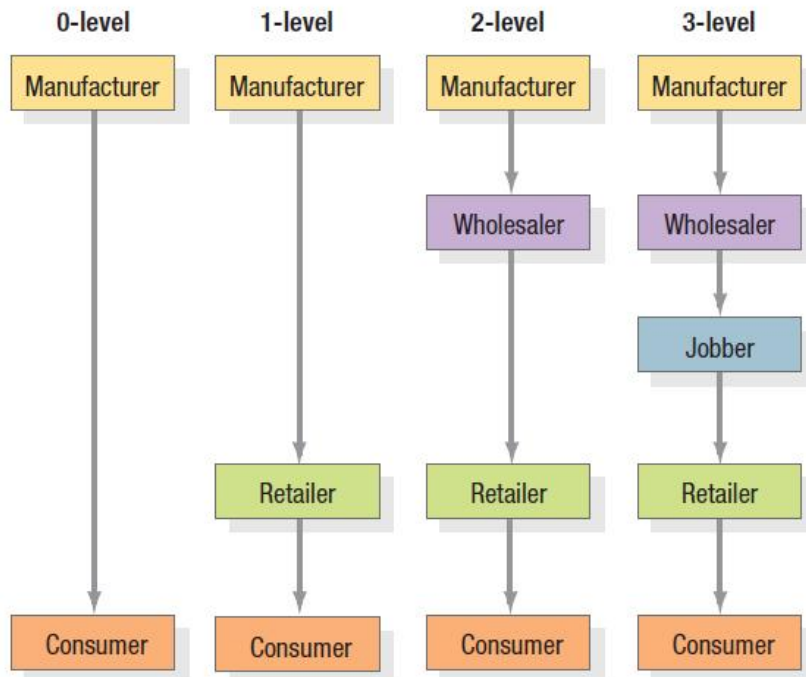

(a) 消费品营销渠道

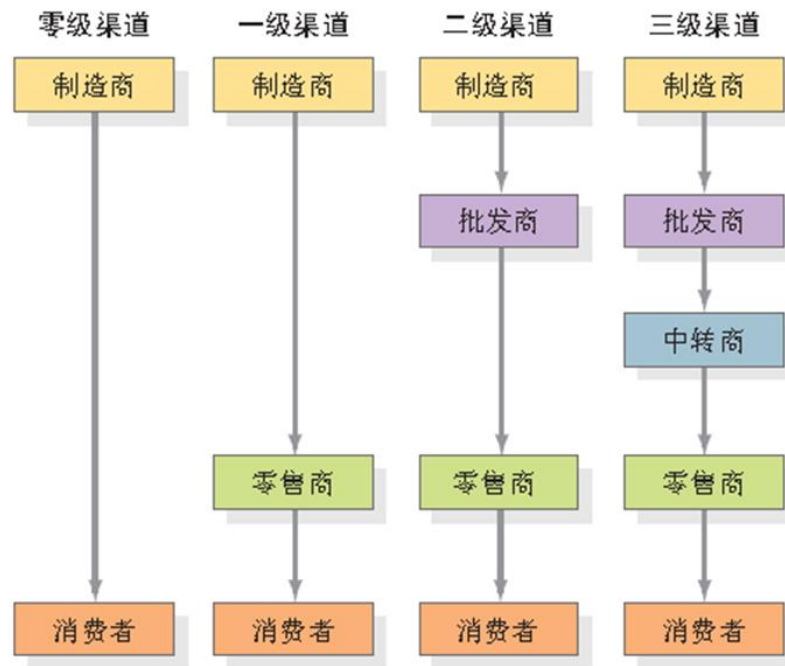

Designing a

Marketing Channel System 设计营销渠道系统 P473

- Analyzing customer needs and wants 分析顾客的需要和欲望
 - ✓ Desired lot size 批量大小
 - ✓ Waiting and delivery time 等候和交货时间
 - ✓ Spatial convenience 空间便利
 - ✓ Product variety 产品多样性
 - ✓ Service backup 服务支持
- Establishing channel objectives and constraints 确立渠道目标和约束

Identifying Channel Alternatives

识别渠道方案 P475

- Types of intermediaries 中间商的类型 (长度)

- Number

- Exclusive
- Selective
- Intensive

- Terms α

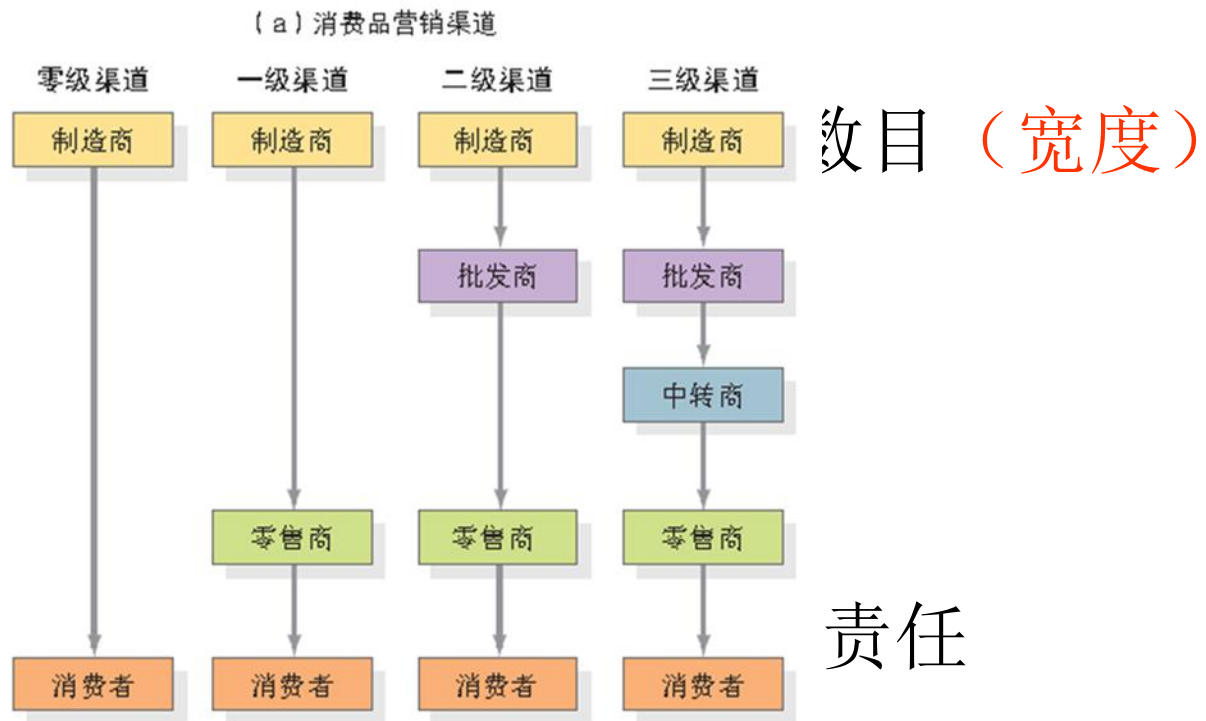

Evaluating Major Channel Alternatives 评估主要渠道方案

- Economic criteria 经济性标准

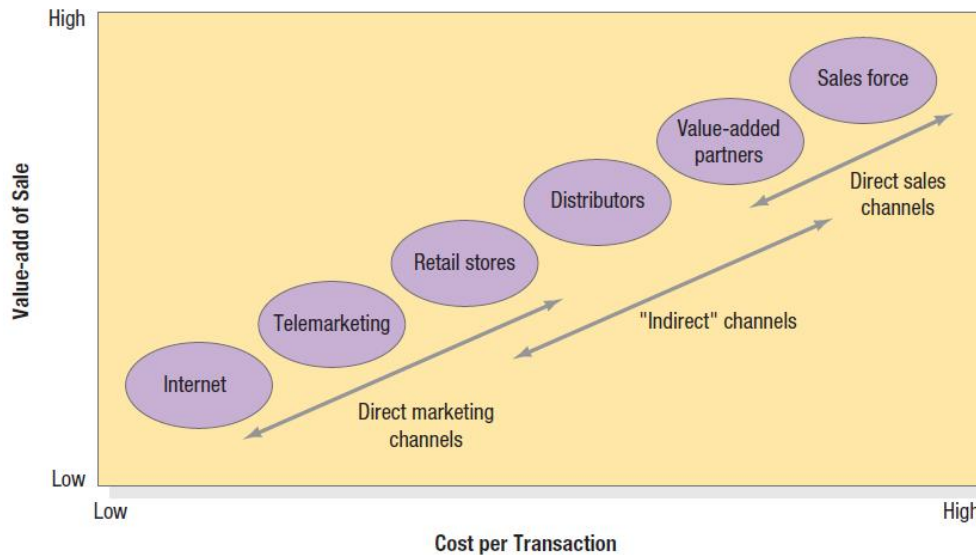

- Control and adaptive criteria 可控性和适应性标准

Channel-Management Decisions

渠道管理决策 P478

- Selecting channel members 挑选渠道成员
 - Training and Motivating channel members 培训和激励渠道成员
 - Evaluating channel members 评价渠道成员
- 第三方飞行
- Modifying channel design and arrangements 改进渠道设计和安排



- Thanks

